

**TABLE OF CONTENTS**

**COPPER SUBSTATION**

Introduction . . . . . **L-3**



Type **NA**  
Tube to Flat . . . . . **L-4**



Type **XA**  
Tube to Flat, Expandable . . . **L-4**



Types **NAS, NAH**  
Cable to Flat (Terminal) . . . . **L-5**

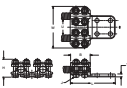

Type **N2AH**  
Two Cables to Flat . . . . . **L-6**



Types **VA, VVA**  
Cable to Flat (Terminal) . . . . **L-7**



Type **NT**  
Tube to Tube . . . . . **L-8**



Types **NSNT, NHNT**  
Tube to Cable . . . . . **L-9**



Types **NSNT, NHNT**  
Cable to Cable . . . . . **L-10**



Type **VT**  
Cable to Cable . . . . . **L-11**



Type **NS**  
Tube to Tube . . . . . **L-11**



Type **XP**  
Tube to Tube . . . . . **L-12**



Type **UH**  
Bus Support, Tube . . . . . **L-13**



Type **UHR**  
Bus Support,  
Tube or Cable . . . . . **L-13**



Types **LH, LHR**  
Bus Support,  
Tube or Cable . . . . . **L-14**



Type **NDR**  
Stud Connector, Cable,  
Tube, Flat Bar . . . . . **L-15**

L-1

Blue highlighted items are industry standard and most frequently ordered.

**TABLE OF CONTENTS** (Continued)

	Type <b>FD</b> Stud Connector, Stud to Flat Bar . . . . . <b>L-16</b>		Type <b>NS-A</b> Tube to Tube . . . . . <b>L-24</b>
	Type <b>QGFL</b> Bar Tap, Cable to Flat . . . . . <b>L-17</b>		Type <b>NA-A</b> Tube to Flat . . . . . <b>L-25</b>
	Type <b>FCB</b> Transformer Tap Adapter . . . <b>L-17</b>		Type <b>XA-A</b> Tube to Flat . . . . . <b>L-25</b>
	Type <b>E-C-G</b> Transformer Tap Adapter . . <b>L-18</b>		Type <b>NBC-A</b> Tube to Flat . . . . . <b>L-26 -L-27</b>
	Type <b>HFBW</b> Bar Clamp . . . . . <b>L-19</b>		Type <b>NAR-A</b> Cable to Flat . . . . . <b>L-28</b>
	Type <b>HFB-P1</b> Bar Clamp . . . . . <b>L-20</b>		Type <b>UHG-A</b> Bus Support, Tube . . . . . <b>L-29</b>
	Type <b>HFB-N</b> Tap Pad Adapter . . . . . <b>L-21</b>		Type <b>UHKR-A</b> Bus Support, Tube or Cable . . . . . <b>L-29</b>
	Type <b>FN</b> . . . . . <b>L-21</b>		Type <b>LB-A</b> End Cap, Aluminum Tube . . <b>L-30</b>
<b>ALUMINUM SUBSTATION</b>			Type <b>WAS-A</b> Terminal Connector . . . . . <b>L-31</b>
	Type <b>NNT-A</b> Tube to Tube . . . . . <b>L-23</b>		Type <b>WASC-A-N</b> Centerformed Terminal . . . . <b>L-32</b>
	Type <b>NNTR-A</b> Tube to Cable, Cable to Cable. . . <b>L-23 - L-24</b>		Type <b>WG-A</b> Weldment Ground Stud . . . <b>L-33</b>

L-2

Blue highlighted items are industry standard and most frequently ordered.

## COPPER SUBSTATION CONNECTORS

### INTRODUCTION

BURNDY® electrical connectors are designed to be installed with a minimum of effort, to run cooler than the conductors being joined and to provide optimum performance under all operating conditions.

To achieve this type of performance, extensive research and development time is spent by BURNDY® engineers and scientists to improve manufacturing techniques, materials and designs. As these improvements become available, they are incorporated into both existing and new product lines. This continuous program of product innovation and improvement insures that, as new and more critical applications evolve, high quality connectors from BURNDY® will be available to meet the need.

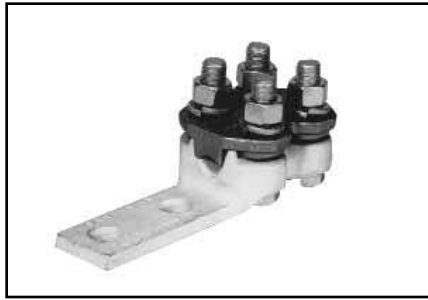

N-Line connectors are two-piece copper alloy castings assembled with DURIMUM™ (silicon bronze) hex bolts, nuts and washers. They are available for connecting tube or cable.

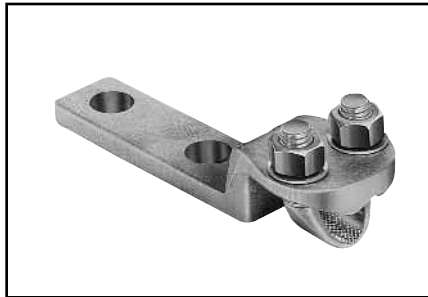

The Variline incorporates a modified V-bolt as the clamping element for heavy-duty applications. This line is particularly suited for use with flexible and extra flexible cables.

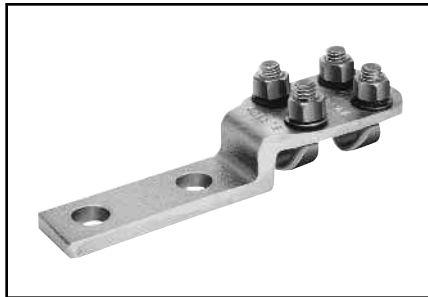

Flat pad connectors used to join cable or tubing terminals to equipment studs.



A variety of bus supports are also available for tube or cable. Some can be adjusted for either a rigid or slide-fit by rotating the clamping cap 180°.

Expansion connectors are used to absorb the stress imposed on the bus by settling ground, thermal expansion and shocks, as in circuit breaker operations. The flexible elements are flat-tinned, copper braid, with sufficient cross sectional area to carry the rated current of the conductors being joined.

Blue highlighted items are industry standard and most frequently ordered.

## TYPE NA

### TERMINAL

For Copper Tube to Flat

High copper alloy terminal for joining copper tube to a flat pad. Letter "N" on end of catalog number indicates pad drilled to NEMA standards. One-wrench installation.

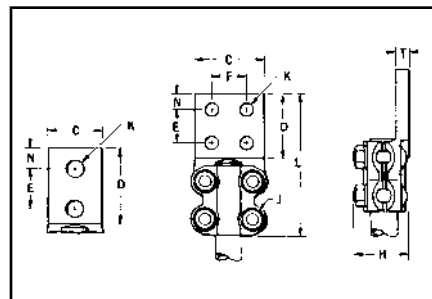

Catalog Number	Conductor	No. of Holes in Pad	C	D	E & F	H	J	K	L	N	T	
NA13-2N	1/2	2	1-1/2	3	1-3/4	1-3/4	3/8	9/16	5-1/4	5/8	3/8	
NA14-2N	3/4	2	1-5/8			2	3/8				3/8	
NA15-2N	1	2	1-7/8			2-1/8	3/8				3/8	
NA15-4N	1	4	3			2-1/8	3/8				3/8	
NA16-2N	1-1/4	2	2-1/4			2-5/8	1/2				1/2	
NA16-4N	1-1/4	4	3			2-5/8	1/2				1/2	
NA17-2N	1-1/2	2	2-1/2			2-3/4	1/2		1/2		6	1/2
NA17-4N	1-1/2	4	3			2-3/4	1/2		1/2			
NA18-4N	2	4	3-1/8			3-1/	1/2		1/2			
NA19-4N	2-1/2	4	3-1/4			3-3/4	1/2		1/2			
NA21-4N	3-1/2	4	4-3/8			5	5/8		5/8			
NA22-4N	4	4	5-1/4			5-1/2	5/8		5/8			

## TYPE XA

### EXPANSION TERMINAL

For Copper Tube to Flat

High copper alloy expansion terminal for tube to flat. Provides for longitudinal movement of tubing. Extra flexible braid carries full load of joint. One-wrench installation.

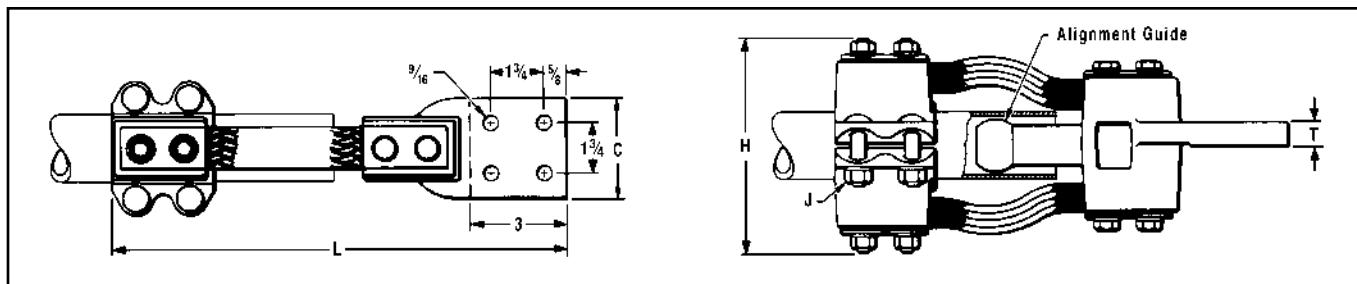

Catalog Number Standard I.P.S. With Guide	Conductor	Number of Holes in Pad*	C	H	J	L	T
XA18-4N	2	4	3	7	1/2	15-1/4	1/2
XA19-4N	2-1/2		3-3/4	7-1/2		16-1/8	5/8
XA20-4N	3		4-3/8	8	5/8	16-3/4	3/4
XA21-4N	3-1/2		4-3/4	8-1/4		17	7/8
XA22-4N	4		5-1/4	9-1/2		17	7/8

\* Conforms to NEMA Standards

Blue highlighted items are industry standard and most frequently ordered.

**TYPES NAS, NAH**

**TERMINAL**

For Copper Cable

High copper alloy reversible cap terminal for joining a wide range of cable to equipment pads. Tongue is side formed to provide adequate clearance and terminal is designed for one-wrench installation.

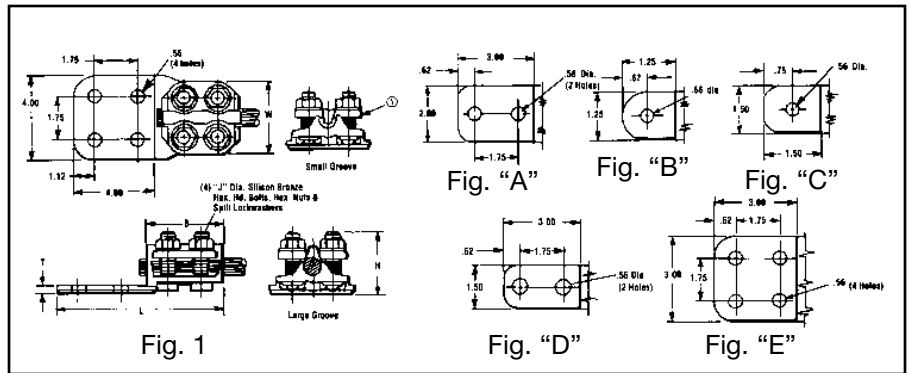

Catalog Number	Fig. No.	Copper Cable Range			B	H	J Dia.	L	T	W
		Complete Cable Range	Small Groove	Large Groove						
NAS29-N	1B				2.38	1.80	3/8"-16	3.58		2.00
NAS29-2N	1D	6 Sol. (.162 Dia.) to 250 kcmil (.575 Dia.)	6 Sol. (.162 Dia.) to 1/0 Str. (.373 Dia.)	2/0 Str. (.419 Dia.) to 250 kcmil (.575 Dia.)	2.62	2.12	1/2"-13	5.88	.25	2.44
NAS29-34N	1E				2.38	1.80	3/8"-16	5.62		2.00
NAS34-N	1C				2.38	2.05	3/8"-16	4.12		2.20
NAS34-2N	1A	1/0 Sol. (.325 Dia.) to 500 kcmil (.813 Dia.)	1/0 Sol. (.325 Dia.) to 4/0 Str. (.529 Dia.)	250 kcmil (.575 Dia.) to 500 kcmil (.813 Dia.)	2.62	2.38	1/2"-13	5.88	.31	2.56
NAH34-2N	1A				2.38	2.05	3/8"-16	5.62		2.20
NAS34-34N	1E				2.30	1.75	1/2"-13	5.88	.25	2.56
NAH34-34N	1E				2.30	1.75	3/8"-16			
NAS40-2N	1A	2/0 Sol. (.365 Dia.) to 800 kcmil (1.031 Dia.)	2/0 Sol. (.365 Dia.) to 500 kcmil (.813 Dia.)	500 kcmil (.813 Dia.) to 800 kcmil (1.031 Dia.)	2.62	2.62	1/2"-13	6.88	.38	2.44
NAH40-2N	1A						1/2"-13			2.81
NAS40-34N	1E						3/8"-16			2.44
NAH40-34N	1E						1/2"-13			2.44
NAH40-44N	1							.31	2.44	
NAH44-2N	1A	4/0 Str. (.528 Dia.) to 1000 kcmil (1.152 Dia.)	4/0 Str. (.528 Dia.) to 750 kcmil (.998 Dia.)	750 kcmil (.998 Dia.) to 1000 kcmil (1.152 Dia.)	2.88	2.62	1/2"-13		6.88	2.81
NAH44-34N	1E									
NAH44-44N	1							.44	2.88	
NAH46-2N	1A	1000 kcmil (1.152 Dia.) to 1500 kcmil (1.412 Dia.)	—	1000 kcmil (1.152 Dia.) to 1500 kcmil (1.412 Dia.)	3.06	2.88	1/2"-13			6.12
NAH46-34N	1E							7.12	.31	
NAH46-44N	1							6.31	.50	
NAH48-2N	1A	500 kcmil (.813 Dia.) to 2000 kcmil (1.632 Dia.)	500 kcmil (.813 Dia.) to 1500 kcmil (1.412 Dia.)	1500 kcmil (1.412 Dia.) to 2000 kcmil (1.632 Dia.)	3.25	3.12	1/2"-13	7.31	.38	
NAH48-34N	1E							6.50	.69	
NAH48-44N	1							7.50	.50	
								.44	3.38	

L-5

Blue highlighted items are industry standard and most frequently ordered.

**TYPE N2AH**

**TERMINAL**

For Two Copper Cables to Flat

High copper alloy, reversible cap terminal for joining a wide range of two copper cables to equipment pads. Tongue is side formed to provide adequate clearance and terminal is designed for one-wrench installation.

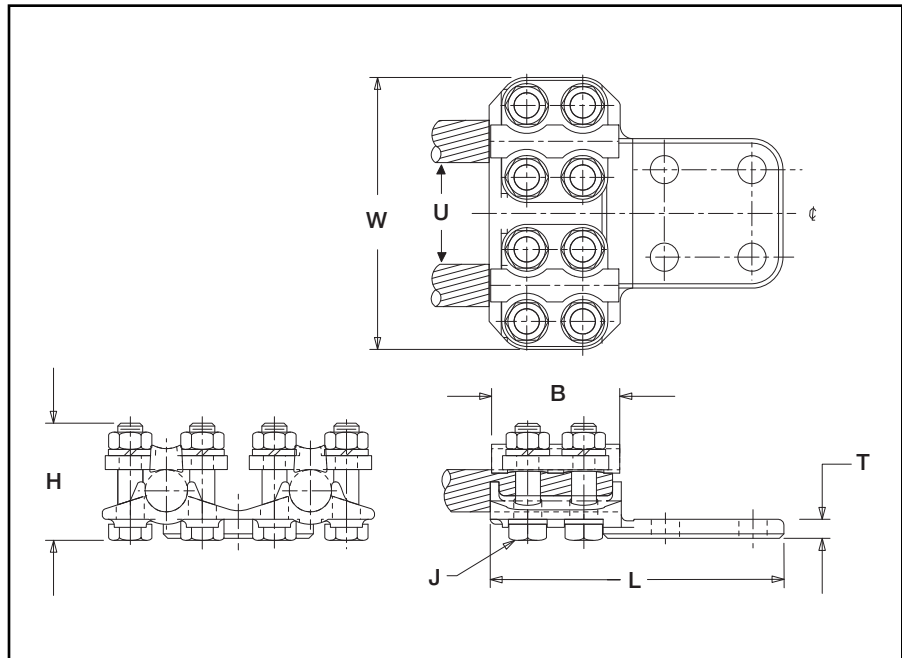

Catalog Number	Fig. No.	Copper Cable Range			Dimensions Inches/[mm]						
		Complete Cable Range	Small Groove	Large Groove	B	H	U	J Dia.	L	T	W
N2AH34-34N	1	1/0 Str. (.325) to 500 kcmil (.813)	1/0 Sol. (.325) to 4/0 Str. (.529)	250 kcmil (.575) to 500 kcmil (.813)	2.63 [67]	2.30 [58]	2.88	1/2 - 13	6.13 [156]	.31 [8]	3.88 [99]
N2AH40-34N	1	2/0 Str. (.420) to 800 kcmil (1.031)	2/0 Str. (.420) to 500 kcmil (.813)	500 kcmil (.813) to 800 kcmil (1.031)	2.63 [67]	2.62 [67]	2.92		5.88 [149]	.31 [8]	5.70 [145]
N2AH44-34N	1	4/0 Str. (.529) to 1000 kcmil (1.152)	4/0 Str. (.529) to 750 kcmil (.998)	750 kcmil (.998) to 1000 kcmil (1.152)	2.88 [73]	2.62 [67]	3.12		6.38 [175]	.50 [13]	4.69 [119]
N2AH44-44N	2	4/0 Str. (.529) to 1000 kcmil (1.152)	4/0 Sol. (.529) to 750 kcmil (.998)	750 kcmil (.998) to 1000 kcmil (1.152)	2.88 [73]	2.25 [57]	3.12		7.32 [186]	.50 [13]	6.12 [155]
N2AH46-44N	2	1000 kcmil (1.152) to 1500 kcmil (1.411)	—	—	3.07 [78]	2.50 [64]	3.36		7.46 [189]	.75 [19]	6.50 [165]

L-6

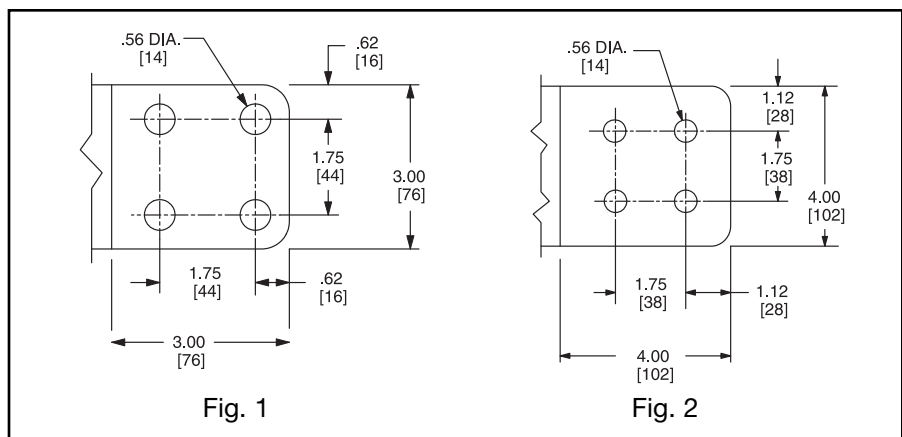

Blue highlighted items are industry standard and most frequently ordered.

**TYPES VA, VVA**

**VARILUG**

For Copper Cable

High copper alloy terminal for joining a wide range of cable to equipment pads or bar. Particularly suitable for use on extra flexible cable. One-wrench installation. Type VVA, twin elements secure joint against vibration and flexing. Particularly recommended for use on extra flexible cables. One-wrench installation.

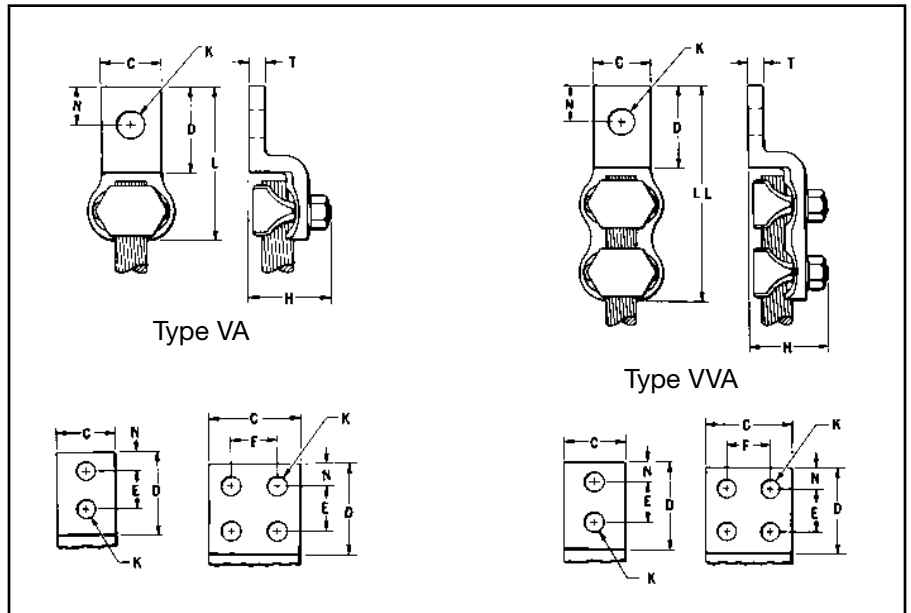
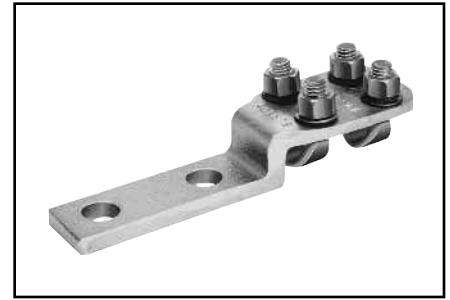
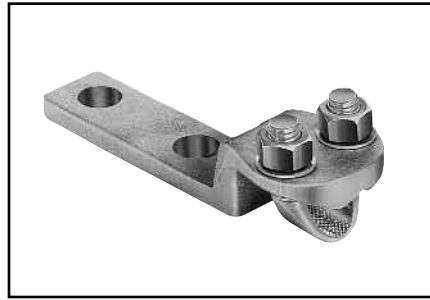

Catalog Number*		Conductor	No. of Holes in Pad	C	D	E & F	H	K	L	LL	N	T
Type VA	Type VVA											
VA2C	—	8 Sol. - 2 Str.	1	13/16	1-1/4	—	1-1/2	7/16	2-3/4	4-1/8	3/8	1/4
VA25	—	6 Sol. - 1/0 Str.		7/8	1-3/8	—	1-7/8		2-1/8	4-3/8	1/2	
VA28	VVA28	1/0 Str. - 4/0 Str.	1	1-1/16	1-1/2	—	1-7/8	7/16	2-5/8	4-1/8	1/2	5/16
VA28-2N	VVA28-2N		2 NEMA		3-1/2	1-3/4			9/16	5	6-1/4	
VA30	VVA30	1/0 Str. - 300	1	1-1/8	1-5/8	—	2-1/4	7/16	3-1/4	4-5/8	5/8	3/8
VA30-2N	VVA30-2N		2 NEMA		3-5/8	1-3/4			9/16	5-1/4	6-5/8	
VA34	VVA34	300 - 500	1	1-3/8	2	—	2-5/8	9/16	3-7/8	5-3/8	7/8	3/8
VA34-2N	VVA34-2N		2 NEMA		3-5/8	1-3/4			9/16	5-3/8	6-1/8	
—	VVA34-4N		4 NEMA	3	3-1/16	1-3/4	2-9/16	9/16	5-3/8	6-7/8	5/8	
VA40	VVA40	500 - 800	1	1-5/8	2-3/8	—	2-1/8	9/16	4-1/2	6-3/8	1	3/8
VA40-2N	VVA40-2N		2 NEMA		3-5/8	1-3/4			9/16	5-7/8	7-3/4	
VA40-4N	VVA40-4N		4 NEMA	3	2-5/8	1-3/4	9/16	5-7/8	7-3/4	5/8		

\* "N" indicates NEMA standard stud holes.

Blue highlighted items are industry standard and most frequently ordered.

**TYPE NT**

**T-CONNECTOR**

For Copper Tube to Tube

High copper alloy T-Connector for tubing run and tap. Slots between bolts provide independent high-pressure areas of contact. One-wrench installation.

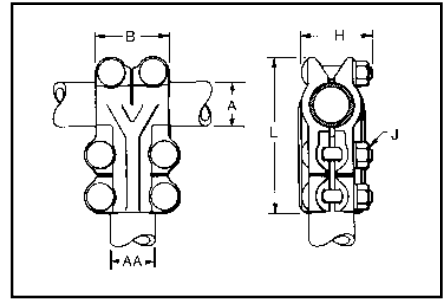
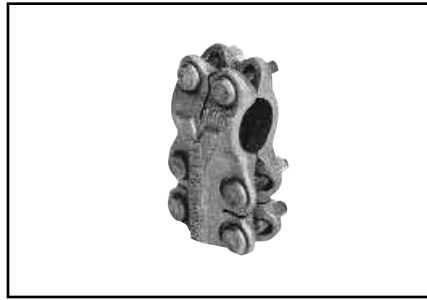

Catalog Number	Conductor		B	H	J	L		
	Run 'A'	Tap 'AA'						
NT1313	1/2"	1/2"	2"	1-3/4"	3/8"	4"		
NT1413	3/4"	1/2"		2"		4-1/8"		
NT1414		3/4"		4-3/8"				
NT1514		3/4"		4-1/2"				
NT1515	1"	1"		2-1/8"		4-3/4"		
NT1614	1-1/4"	3/4"		2-1/2"		4-3/4"		
NT1615		1"		2-5/8"		5-3/4"		
NT1616		1-1/4"		2-3/4"		1/2"	5-3/4"	
NT1714	1-1/2"	3/4"		2"		2-3/4"	3/8"	5-1/8"
NT1715		1"		2-3/4"		1/2"	6-1/8"	
NT1717		1-1/2"						
NT1816		1-1/4"						
NT1817	2"	1-1/2"	3-1/4"	6-5/8"				
NT1818		2"	3-1/8"	3-3/8"	6-3/4"			
NT1919	2-1/2"	2-1/2"	3-5/8"	3-7/8"	7-1/4"			
NT2020	3"	3"	4-3/8"	4-5/8"	8-5/8"			
NT2121	3-1/2"	3-1/2"	4-7/8"	5-1/4"	9-1/4"			
NT2222	4"	4"	5-1/2"	5-3/4"	9-7/8"			

Blue highlighted items are industry standard and most frequently ordered.



TYPES NSNT, NHNT

T-CONNECTOR

For Copper Tube to Cable

High copper alloy T-Connector for joining copper tubing run to a wide range of copper tap cable. Tap utilizes reversible cap to achieve large conductor range and the connector is designed for one-wrench installation.

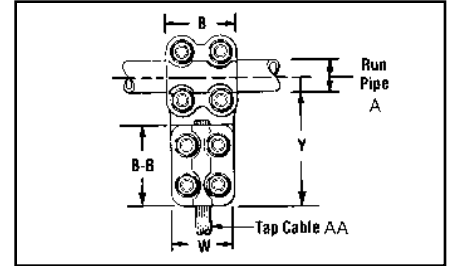
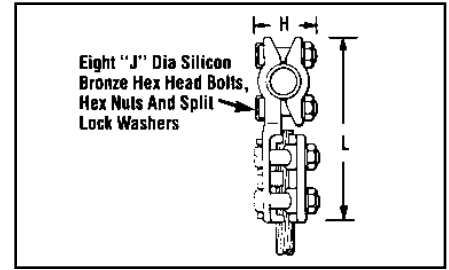

Catalog Number	Run IPS or EHPS A	Commercial Copper Cable Range			B	B-B	H	"J" Dia.	L	W	Y
		Complete ① Tap Cable Range AA	Small Tap Groove	Large Tap Groove							
NSNT1329	1/2" (.840 Dia.)	6 Sol. (.162 Dia.) to 250 kcmil (.575 Dia.)	6 Sol. (.162 Dia.) to 1/0 Str. (.372 Dia.)	2/0 Str. (.420 Dia.) to 250 kcmil (.575 Dia.)	2.00	2.38	2.00	3/8"-16	5.08	1.96	3.89
NHNT1329		6 Sol. (.162 Dia.) to 250 kcmil (.575 Dia.)	1/0 Str. (.372 Dia.) to 250 kcmil (.575 Dia.)	250 kcmil (.575 Dia.) to 2/0 Str. (.420 Dia.)	2.25	2.62	2.32	1/2"-13	5.82	2.44	4.38
NSNT1429	3/4" (1.050 Dia.)	6 Sol. (.162 Dia.) to 250 kcmil (.575 Dia.)	6 Sol. (.162 Dia.) to 1/0 Str. (.372 Dia.)	2/0 Str. (.420 Dia.) to 250 kcmil (.575 Dia.)	2.00	2.38	2.00	3/8"-16	5.08	1.96	3.89
NHNT1429		6 Sol. (.162 Dia.) to 250 kcmil (.575 Dia.)	1/0 Str. (.372 Dia.) to 250 kcmil (.575 Dia.)	250 kcmil (.575 Dia.) to 2/0 Str. (.420 Dia.)	2.25	2.62	2.32	1/2"-13	5.82	2.44	4.38
NSNT1434	1" (1.315 Dia.)	1/0 Sol. (.325 Dia.) to 500 kcmil (.813 Dia.)	1/0 Sol. (.325 Dia.) to 4/0 Str. (.529 Dia.)	250 kcmil (.575 Dia.) to 500 kcmil (.813 Dia.)	2.00	2.38	2.10	3/8"-16	5.08	2.20	3.89
NHNT1434		1/0 Sol. (.325 Dia.) to 500 kcmil (.813 Dia.)	4/0 Str. (.529 Dia.) to 500 kcmil (.813 Dia.)	500 kcmil (.813 Dia.) to 2/0 Str. (.420 Dia.)	2.25	2.62	2.42	1/2"-13	5.82	2.56	4.38
NSNT1529	1" (1.315 Dia.)	6 Sol. (.162 Dia.) to 250 kcmil (.575 Dia.)	6 Sol. (.162 Dia.) to 1/0 Str. (.372 Dia.)	2/0 Str. (.420 Dia.) to 250 kcmil (.575 Dia.)	2.00	2.38	2.00	3/8"-16	5.34	1.96	4.02
NHNT1529		6 Sol. (.162 Dia.) to 250 kcmil (.575 Dia.)	1/0 Str. (.372 Dia.) to 250 kcmil (.575 Dia.)	250 kcmil (.575 Dia.) to 2/0 Str. (.420 Dia.)	2.25	2.62	2.57	1/2"-13	5.92	2.44	4.43
NHNT1534	1" (1.315 Dia.)	1/0 Sol. (.325 Dia.) to 500 kcmil (.813 Dia.)	1/0 Sol. (.325 Dia.) to 4/0 Str. (.529 Dia.)	250 kcmil (.575 Dia.) to 500 kcmil (.813 Dia.)	2.25	2.62	2.57	1/2"-13	5.92	2.56	4.43
NHNT1540		2/0 Str. (.420 Dia.) to 800 kcmil (1.031 Dia.)	2/0 Str. (.420 Dia.) to 500 kcmil (.813 Dia.)	500 kcmil (.813 Dia.) to 800 kcmil (1.031 Dia.)	2.60	2.68	2.60	—	2.78	—	—
NSNT1629	1-1/4" (1.660 Dia.)	6 Sol. (.162 Dia.) to 250 kcmil (.575 Dia.)	6 Sol. (.162 Dia.) to 1/0 Str. (.372 Dia.)	2/0 Str. (.420 Dia.) to 250 kcmil (.575 Dia.)	2.00	2.38	2.37	3/8"-16	5.78	1.96	4.24
NHNT1629		6 Sol. (.162 Dia.) to 250 kcmil (.575 Dia.)	1/0 Str. (.372 Dia.) to 250 kcmil (.575 Dia.)	250 kcmil (.575 Dia.) to 2/0 Str. (.420 Dia.)	2.25	2.62	2.57	—	2.44	—	—
NHNT1634	1-1/4" (1.660 Dia.)	1/0 Sol. (.325 Dia.) to 500 kcmil (.813 Dia.)	1/0 Sol. (.325 Dia.) to 4/0 Str. (.529 Dia.)	250 kcmil (.575 Dia.) to 500 kcmil (.813 Dia.)	2.69	2.62	2.60	6.32	2.56	4.63	
NHNT1640		2/0 Str. (.420 Dia.) to 800 kcmil (1.031 Dia.)	2/0 Str. (.420 Dia.) to 500 kcmil (.813 Dia.)	500 kcmil (.813 Dia.) to 800 kcmil (1.031 Dia.)	2.69	2.68	2.68	6.32	2.78	—	—
NHNT1644	4/0 Str. (.529 Dia.) to 1000 kcmil (1.152 Dia.)	4/0 Str. (.529 Dia.) to 750 kcmil (.998 Dia.)	750 kcmil (.998 Dia.) to 1000 kcmil (1.152 Dia.)	2.88	2.69	2.69	6.58	2.90	4.89	—	
NHNT1729	1-1/2" (1.900 Dia.)	6 Sol. (.162 Dia.) to 250 kcmil (.575 Dia.)	6 Sol. (.162 Dia.) to 1/0 Str. (.372 Dia.)	210 Str. (.420 Dia.) to 250 kcmil (.575 Dia.)	2.69	2.62	2.70	6.76	2.44	4.85	
NHNT1734		1/0 Sol. (.325 Dia.) to 500 kcmil (.813 Dia.)	1/0 Sol. (.325 Dia.) to 4/0 Str. (.529 Dia.)	250 kcmil (.575 Dia.) to 500 kcmil (.813 Dia.)	2.69	2.62	2.70	6.76	2.56	4.85	
NHNT1740	1-1/2" (1.900 Dia.)	2/0 Str. (.420 Dia.) to 800 kcmil (1.031 Dia.)	2/0 Str. (.420 Dia.) to 500 kcmil (.813 Dia.)	500 kcmil (.813 Dia.) to 800 kcmil (1.031 Dia.)	2.69	2.62	2.78	6.76	2.78	—	
NHNT1744		4/0 Str. (.529 Dia.) to 1000 kcmil (1.152 Dia.)	4/0 Str. (.529 Dia.) to 750 kcmil (.998 Dia.)	750 kcmil (.998 Dia.) to 1000 kcmil (1.152 Dia.)	2.88	2.80	2.80	7.02	2.90	5.11	
NHNT1829	2" (2.375 Dia.)	6 Sol. (.162 Dia.) to 250 kcmil (.575 Dia.)	6 Sol. (.162 Dia.) to 1/0 Str. (.372 Dia.)	2/0 Str. (.420 Dia.) to 250 kcmil (.575 Dia.)	2.69	2.62	3.06	7.44	2.44	5.19	
NHNT1834		1/0 Sol. (.325 Dia.) to 500 kcmil (.813 Dia.)	1/0 Sol. (.325 Dia.) to 4/0 Str. (.529 Dia.)	250 kcmil (.575 Dia.) to 500 kcmil (.813 Dia.)	2.69	2.62	3.06	7.44	2.56	5.19	
NHNT1840	2" (2.375 Dia.)	2/0 Str. (.420 Dia.) to 800 kcmil (1.031 Dia.)	2/0 Str. (.420 Dia.) to 500 kcmil (.813 Dia.)	500 kcmil (.813 Dia.) to 800 kcmil (1.031 Dia.)	2.69	2.62	3.06	7.44	2.78	—	
NHNT1844		4/0 Str. (.529 Dia.) to 1000 kcmil (1.152 Dia.)	4/0 Str. (.529 Dia.) to 750 kcmil (.998 Dia.)	750 kcmil (.998 Dia.) to 1000 kcmil (1.152 Dia.)	2.88	3.06	3.06	7.70	2.90	5.45	
NHNT1846	1000 kcmil (1.152 Dia.) to 1500 kcmil (1.412 Dia.)	—	1000 kcmil (1.152 Dia.) to 1500 kcmil (1.412 Dia.)	3.06	3.23	3.23	7.88	3.16	5.63	—	
NHNT1929	2-1/2" (2.875 Dia.)	6 Sol. (.162 Dia.) to 250 kcmil (.575 Dia.)	6 Sol. (.162 Dia.) to 1/0 Str. (.372 Dia.)	2/0 Str. (.420 Dia.) to 250 kcmil (.575 Dia.)	2.69	2.62	3.64	8.06	2.44	5.50	
NHNT1934		1/0 Sol. (.325 Dia.) to 500 kcmil (.813 Dia.)	1/0 Sol. (.325 Dia.) to 4/0 Str. (.529 Dia.)	250 kcmil (.575 Dia.) to 500 kcmil (.813 Dia.)	2.69	2.62	3.64	8.06	2.56	5.50	
NHNT1940	2-1/2" (2.875 Dia.)	2/0 Str. (.420 Dia.) to 800 kcmil (1.031 Dia.)	2/0 Str. (.420 Dia.) to 500 kcmil (.813 Dia.)	500 kcmil (.813 Dia.) to 800 kcmil (1.031 Dia.)	2.69	2.62	3.64	8.06	2.78	—	
NHNT1944		4/0 Str. (.529 Dia.) to 1000 kcmil (1.152 Dia.)	4/0 Str. (.529 Dia.) to 750 kcmil (.998 Dia.)	750 kcmil (.998 Dia.) to 1000 kcmil (1.152 Dia.)	2.88	3.06	3.06	8.32	2.90	5.76	
NHNT1946	1000 kcmil (1.152 Dia.) to 1500 kcmil (1.412 Dia.)	—	1000 kcmil (1.152 Dia.) to 1500 kcmil (1.412 Dia.)	3.06	3.06	3.06	8.50	3.16	5.94	—	
NHNT2044	3" (3.500 Dia.)	4/0 Str. (.529 Dia.) to 1000 kcmil (1.152 Dia.)	4/0 Str. (.529 Dia.) to 750 kcmil (.998 Dia.)	750 kcmil (.998 Dia.) to 1000 kcmil (1.152 Dia.)	5.75	4.26	4.26	8.95	2.90	6.07	

① Complete cable range may be accommodated by reversing cap.

Blue highlighted items are industry standard and most frequently ordered.

## TYPES NSNT, NHNT

### T-CONNECTOR

For Copper Cable to Cable

High copper alloy reversible T-Connector for joining a wide range of run and tap cables. Connector is designed for one-wrench installation. “S” standard 3/8” hardware and “H” heavy duty 1/2” hardware.

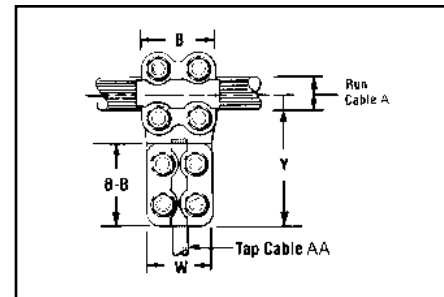
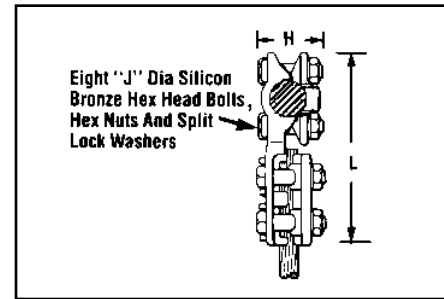

Catalog Number	Commercial Copper Cable Range					
	Complete Run Cable Range A ①	Small Run Groove	Large Run Groove	Complete Tap Cable Range AA ①	Small Tap Groove	Large Tap Groove
NSNT2929	6 Sol. (.162 Dia.) to 250 kcmil (.575 Dia.)	6 Sol. (.162 Dia.) to 1/0 Str. (.372 Dia.)	2/0 Str. (.420 Dia.) to 250 kcmil (.575 Dia.)	6 Sol. (.162 Dia.) to 250 kcmil (.575 Dia.)	6 Sol. (.162 Dia.) to 1/0 Str. (.372 Dia.)	2/0 Str. (.420 Dia.) to 250 kcmil (.575 Dia.)
NHNT2929	1/0 Sol. (.325 Dia.) to 500 kcmil (.813 Dia.)	1/0 Sol. (.325 Dia.) to 4/0 Str. (.529 Dia.)	250 kcmil (.575 Dia.) to 500 kcmil (.813 Dia.)	1/0 Sol. (.325 Dia.) to 500 kcmil (.813 Dia.)	1/0 Sol. (.325 Dia.) to 4/0 Str. (.529 Dia.)	250 kcmil (.575 Dia.) to 500 kcmil (.813 Dia.)
NSNT3429	4/0 Str. (.529 Dia.) to 1000 kcmil (1.152 Dia.)	4/0 Str. (.529 Dia.) to 750 kcmil (.998 Dia.)	750 kcmil (.998 Dia.) to 1000 kcmil (1.152 Dia.)	6 Sol. (.162 Dia.) to 250 kcmil (.575 Dia.)	6 Sol. (.162 Dia.) to 1/0 Str. (.372 Dia.)	2/0 Str. (.420 Dia.) to 250 kcmil (.575 Dia.)
NHNT3429				1/0 Sol. (.325 Dia.) to 500 kcmil (.813 Dia.)	1/0 Sol. (.325 Dia.) to 4/0 Str. (.529 Dia.)	250 kcmil (.575 Dia.) to 500 kcmil (.813 Dia.)
NSNT3434				6 Sol. (.162 Dia.) to 250 kcmil (.575 Dia.)	6 Sol. (.162 Dia.) to 1/0 Str. (.372 Dia.)	2/0 Str. (.420 Dia.) to 250 kcmil (.575 Dia.)
NHNT3434				1/0 Sol. (.325 Dia.) to 500 kcmil (.813 Dia.)	1/0 Sol. (.325 Dia.) to 4/0 Str. (.529 Dia.)	250 kcmil (.575 Dia.) to 500 kcmil (.813 Dia.)
NHNT4429	500 kcmil (.813 Dia.) to 2000 kcmil (1.632 Dia.)	500 kcmil (.813 Dia.) to 1500 kcmil (1.412 Dia.)	1500 kcmil (1.412 Dia.) to 2000 kcmil (1.632 Dia.)	6 Sol. (.162 Dia.) to 250 kcmil (.575 Dia.)	6 Sol. (.162 Dia.) to 1/0 Str. (.372 Dia.)	2/0 Str. (.420 Dia.) to 250 kcmil (.575 Dia.)
NHNT4434				1/0 Sol. (.325 Dia.) to 500 kcmil (.813 Dia.)	1/0 Sol. (.325 Dia.) to 4/0 Str. (.529 Dia.)	250 kcmil (.575 Dia.) to 500 kcmil (.813 Dia.)
NHNT4440				2/0 Str. (.420 Dia.) to 800 kcmil (1.031 Dia.)	2/0 Str. (.420 Dia.) to 500 kcmil (.813 Dia.)	500 kcmil (.813 Dia.) to 800 kcmil (1.031 Dia.)
NHNT4444				4/0 Str. (.529 Dia.) to 1000 kcmil (1.152 Dia.)	4/0 Str. (.529 Dia.) to 750 kcmil (.998 Dia.)	750 kcmil (.998 Dia.) to 1000 kcmil (1.152 Dia.)
NHNT4834	1000 kcmil (1.152 Dia.) to 1500 kcmil (1.412 Dia.)	1000 kcmil (1.152 Dia.) to 1500 kcmil (1.412 Dia.)	1000 kcmil (1.152 Dia.) to 1500 kcmil (1.412 Dia.)	1/0 Sol. (.325 Dia.) to 500 kcmil (.813 Dia.)	1/0 Sol. (.325 Dia.) to 4/0 Str. (.529 Dia.)	250 kcmil (.575 Dia.) to 500 kcmil (.813 Dia.)
NHNT4840				2/0 Str. (.420 Dia.) to 800 kcmil (1.031 Dia.)	2/0 Str. (.420 Dia.) to 500 kcmil (.813 Dia.)	500 kcmil (.813 Dia.) to 800 kcmil (1.031 Dia.)
NHNT4844				4/0 Str. (.529 Dia.) to 1000 kcmil (1.152 Dia.)	4/0 Str. (.529 Dia.) to 750 kcmil (.998 Dia.)	750 kcmil (.998 Dia.) to 1000 kcmil (1.152 Dia.)
NHNT4846				500 kcmil (.813 Dia.) to 2000 kcmil (1.632 Dia.)	500 kcmil (.813 Dia.) to 1500 kcmil (1.412 Dia.)	1500 kcmil (1.412 Dia.) to 2000 kcmil (1.632 Dia.)
NHNT4848	500 kcmil (.813 Dia.) to 2000 kcmil (1.632 Dia.)	500 kcmil (.813 Dia.) to 1500 kcmil (1.412 Dia.)	1500 kcmil (1.412 Dia.) to 2000 kcmil (1.632 Dia.)	500 kcmil (.813 Dia.) to 1500 kcmil (1.412 Dia.)	500 kcmil (.813 Dia.) to 1500 kcmil (1.412 Dia.)	1500 kcmil (1.412 Dia.) to 2000 kcmil (1.632 Dia.)

① Complete cable range may be accommodated by reversing cap.

Catalog Number	B	B-B	H	“J” Dia.	L	W	Y
NSNT2929	2.38	2.38	1.75	3/8”-16	4.60	1.96	3.62
NHNT2929	2.62	2.62	2.07	1/2”-13	5.32	2.44	4.10
NSNT3429	2.38	2.38	2.00	3/8”-16	4.84	1.96	3.74
NHNT3429	2.62	2.62	2.32	1/2”-13	5.44	2.44	4.16
NSNT3434	2.38	2.38	2.00	3/8”-16	4.84	2.20	3.74
NHNT3434	2.62	2.62	2.32	1/2”-13	5.38	2.56	4.10
NHNT4429	2.88	2.62	2.57		5.78	2.44	4.33
NHNT4434					5.78	2.56	
NHNT4440					5.78	2.78	
NHNT4444					6.03	2.90	4.58
NHNT4834	3.25	2.62	3.07		6.26	2.56	4.57
NHNT4840					6.26	2.78	
NHNT4844					6.51	2.90	4.82
NHNT4846					6.76	3.16	5.07
NHNT4848					6.94	3.38	5.25

**TYPE VT**

**T-CONNECTOR**

For Copper Cable to Cable

High copper alloy T-Connector for cable run, cable tap, V-bolt clamping elements accommodate large range of cable and are particularly suited for extra flexible cable. One-wrench installation.

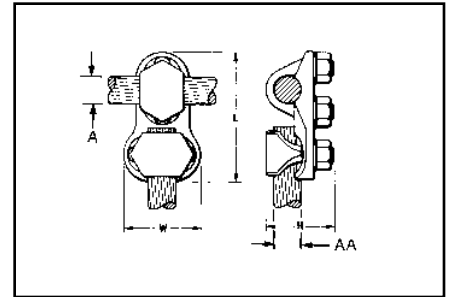

Catalog Number	Conductor		H	L	W
	Run - A	Tap - AA			
VT2C2C	8 Sol. - 2 Str.	8 Sol. - 2 Str.	1-3/8	2-3/8	1
VT2525	6 Sol. - 1/0 Str.	6 Sol. - 1/0 Str.	1-5/8	2-5/8	1-1/4
VT2825	1/0 Str. - 4/0 Str.	6 Sol. - 1/0 Str.		3-1/8	
VT2828	1/0 Str. - 4/0 Str.	1/0 Str. - 4/0 Str.			1-1/8
VT3025	1/0 Str. - 300	6 Sol. - 1/0 Str.	1-7/8	3-3/8	2
VT3030	1/0 Str. - 300	1/0 Str. - 300	2-3/8	3-3/4	1-1/4
VT3425	300 - 500	6 Sol. - 1/0 Str.		3-1/2	1-3/4
VT3428	300 - 500	1/0 Str. - 4/0 Str.		3-5/8	2
VT3430	300 - 500	1/0 Str. - 300		3-3/4	2-1/4
VT3434	300 - 500	300 - 500		2-5/8	4-1/2
VT4040	500 - 800	500 - 800	2-7/8	4-3/8	1-1/4
VT4425	750 - 1000	6 Sol. - 1/0 Str.		4-1/8	1-3/4
VT4428	750 - 1000	1/0 Str. - 4/0 Str.		4-1/4	5-1/4
VT4834	1500 - 2000	300 - 500			

L-11

**TYPE NS**

**COUPLER**

For Copper Tube to Tube

High copper alloy coupler for joining equal sizes of tube end to end. Slots between bolts provide independent high pressure areas of contact. One-wrench installation.

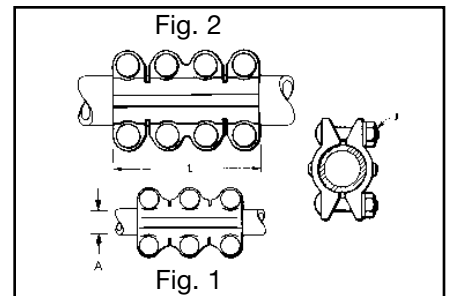

Catalog Number	Conductor - A	Conductor - B	J	L	Fig. No.
NS1313	1/2	1/2	3/8	3-1/4	1
NS1414HC	3/4	3/4		4	
NS1515	1	1		4-1/4	
NS1616HC	1-1/4	1-1/4	1/2	5-3/4	2
NS1717	1-1/2	1-1/2			
NS1818	2	2			
NS1919	2-1/2	2-1/2			
NS2020	3	3	5/8	7-1/4	
NS2121	3-1/2	3-1/2		8	
NS2222	4	4		8-1/2	

Blue highlighted items are industry standard and most frequently ordered.

**TYPE XP**

**EXPANSION COUPLER**

For Copper Tube to Tube

High alloy copper expansion coupler for joining equal size tube on end. Extra flexible tinned copper braid allows longitudinal movement of the tube. Type XP has alignment guide. One-wrench installation.

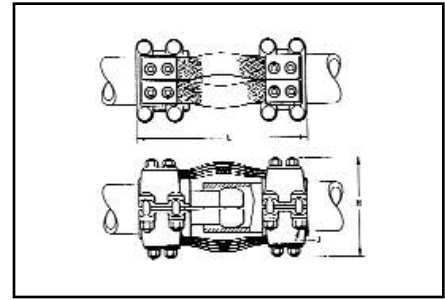
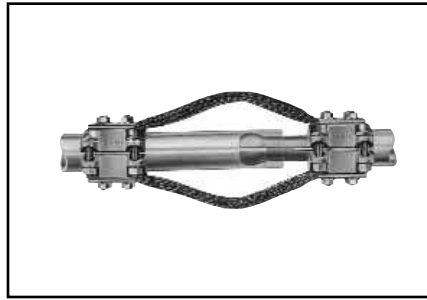

Catalog Number Standard IPS With Guide	Conductor	H	J	L
XP1818	2	7	1/2	12
XP2222	4	9-1/8	5/8	13-5/8

Blue highlighted items are industry standard and most frequently ordered.

**TYPE UH**

**BUS SUPPORT**

For Copper Tube

High copper alloy bus support for mounting tube on a post or pedestal type insulator. Single bolt allows rotation to any angle. Rotate cap 180° for slip or rigid fit. One-wrench installation. Supplied with hardware for mounting to cap of insulator. Specify base mounting hardware, if required, by adding suffix “B” to Catalog No.

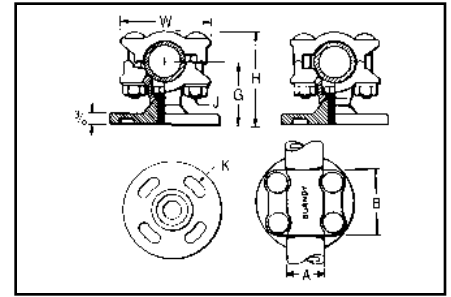
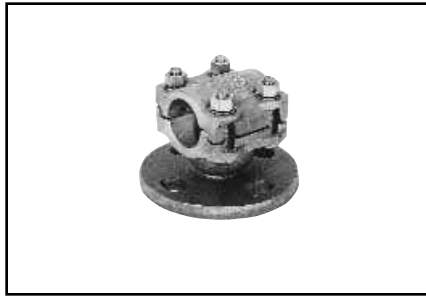

Catalog Number	Copper Conductor IPS “A”	Bolt Circle	B	G	H	J	K	W
UH14-3	3/4	3	2-1/2	2	2-7/8	3/8	9/16	2-5/8
UH15-3	1	3		2	3		9/16	2-7/8
UH15-5		5	2-1/4	3-1/4	11/16			
UH16-3	1-1/4	3		2-11/16	2-3/8	3-5/8	1/2	9/16
UH16-5		5	11/16					
UH17-3	1-1/2	3	3	2-1/2	3-7/8	9/16	4	
UH17-5		5				11/16		
UH18-3	2	3	3	2-3/4	4-3/8	9/16	4-5/8	
UH18-5		5				11/16		
UH19-3	2-1/2	3	3	3-1/8	5	9/16	5-1/4	
UH19-5		5				11/16		
UH20-3	3	3	3-1/4	3-5/8	5-7/8	5/8	9/16	6-1/4
UH20-5		5					11/16	
UH22-5	4	5		4-1/2	7-1/4		11/16	7-1/2

L-13

**TYPE UHR**

**BUS SUPPORT**

For Copper Cable or Tube

High copper alloy bus support clamp for mounting a wide range of cable or tube on post or pedestal type insulators. Single bolt allows rotation to any angle. Supplied with hardware for mounting to cap of insulator. Specify base mounting hardware, if required, by adding suffix “-B” to Catalog No.

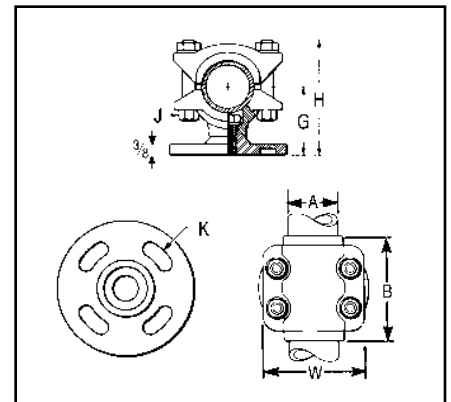

Catalog Number	Copper Conductor “A”		Bolt Circle	B	G*	H	J	K	W
	Cable	Tube							
UHR13-3	6 Str. - 500	1/8 - 1/2	3	3-5/8	1-3/4	3	3/8	9/16	2-1/4
UHR13-5			5		2-1/8	3-3/8		11/16	
UHR15-3	4/0 Str. - 1250	1/4 - 1	3	3-3/4	2	3-1/2		9/16	2-3/4
UHR15-5			5		2-1/4	3-3/4	11/16		
UHR17-3	750 - 2500	3/4 - 1-1/2	3	2-7/8	2-1/2	4-1/4	1/2	9/16	4
UHR17-5			5					11/16	

\* With maximum conductor in place.

Blue highlighted items are industry standard and most frequently ordered.

**TYPES LH, LHR**

**BUS SUPPORT**

For Copper Cable or Tube

High copper alloy, light duty bus support for mounting a wide range of cable or tube on post or pedestal type insulators. One-wrench installation. Supplied with hardware for mounting to cap of insulator. Specify base mounting hardware, if required, by adding suffix “-B” to Catalog No.

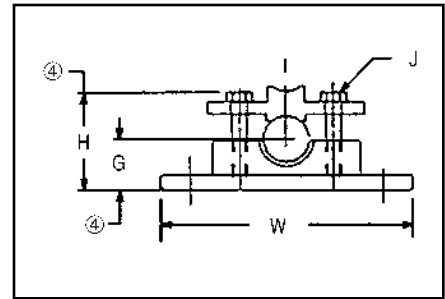
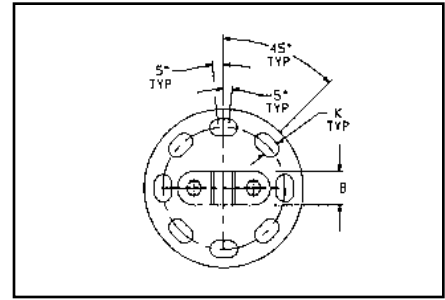
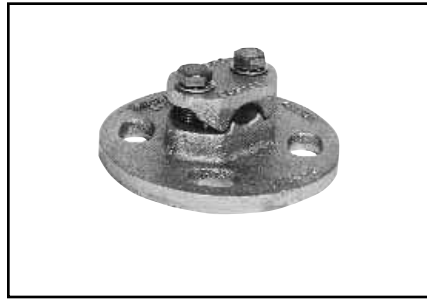

Copper Cable Range Complete Range	Tubing Schedule 40/80	⑤ Bolt ⑥ Circle	Catalog Number	Dimensions Inches/[mm]					
				B	G ④	H ④	J	K	W
6 Sol. - 4/0 Str.	—	3"	<b>LH28-3</b>	1.69 [43]	1.25 [32]	2.62 [66.5]	3/8 - 16	.56 [14]	4.25 [108]
③ #8 - 250 kcmil	1/8 - 1/4	3"	<b>LHR29-3</b>	1.00 [25]	1.23 [31]	2.03 [52]		.56 [14]	4.25 [108]
2/0 Str. - 500 kcmil	1/4 - 1/2	3"	<b>LH34-3</b>	1.38 [35]	1.38 [35]	2.50 [63.5]		.56 [14]	4.25 [108]

L-14

**NOTES:**

- 1 Material:  
 Connector: Cast copper alloy  
 Clamping Hardware: Silicon bronze  
 Mounting Hardware: Galvanized steel
- 2 Dimensions in brackets [ ] are in millimeters.
- ③ Complete range may be accommodated by reversing the cap.
- ④ Dimension with maximum conductor in place.
- ⑤ Cap mounting hardware is supplied as standard. 3.00 Dia. bolt circle furnished with four 1/2 -13 3 1.00 long galvanized steel hex head bolts and split lockwashers. 5.00 Dia. bolt circle furnished as above except bolts are .625 3 1.75.
- ⑥ If base mounting is desired, add “-B” to the Catalog Number and the following hardware will be supplied: 3.00 Dia. bolt circle furnished 1/2 -13 3 1-1/2 long galvanized steel hex head bolt, hex nuts, and 5.00 Dia. bolt circle furnished as above except bolts are .625 3 1.75.

Blue highlighted items are industry standard and most frequently ordered.

**TYPE NDR**

**STUD CONNECTOR**

For Copper Cable,  
Tube, Flat Bar

High copper alloy reversible and rotatable cap stud connector joins cable, tube and flat bar in-line or at right angles to equipment studs. Accommodates a wide range of cables or tubes. One-wrench installation.

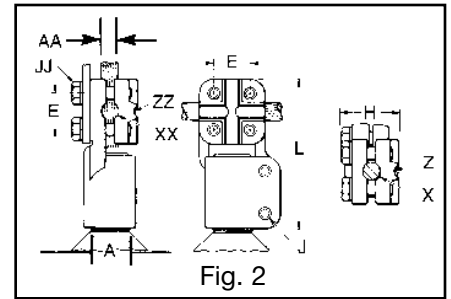
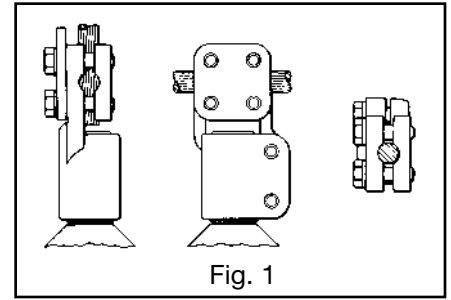
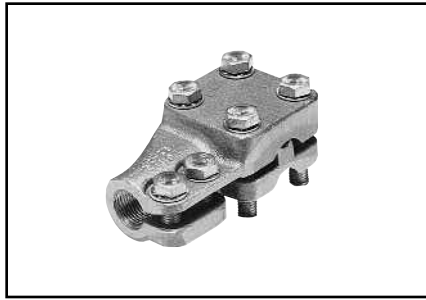

Catalog Number	Stud A	Complete Range AA		Fig. No.	X Groove	XX Groove	Z Groove	ZZ Groove	E	H	J	JJ	L
		Cable	Tube I.P.S.										
NDR6328T13	1/2-13	6 Sol. - 4/0 Str.	—	1	6 Sol. - 1 Str.	2/0 Sol. - 4/0 Str.			1-1/16	1-3/4	3/8	3-5/8	
NDR6428T16		6 Sol. - 4/0 Str.	—		6 Sol. - 1 Str.	2/0 Sol. - 4/0 Str.							
NDR6434T16	3/4-16	6 Sol. - 500	3/8 - 1/2	2	250 - 350	400 - 500	6 Sol. - 2 Str.	1/0 Sol. - 4/0 Str.	1-7/16	2-1/4	3/8	4-1/8	
NDR6444T16		2 Sol. - 1000	3/8 - 3/4		550 - 700	750 - 1000	2 Sol. - 250	300 - 500	1-7/8	2-7/8		1/2	4-5/8
NDR6528T14	1-14	6 Sol. - 4/0 Str.	—	1	6 Sol. - 1 Str.	2/0 Sol. - 4/0 Str.			1-1/16	1-3/4	3/8	4-1/8	
NDR6534T14		6 Sol. - 500	3/8 - 1/2	2	250 - 350	400 - 500	6 Sol. - 2 Str.	1/0 Sol. - 4/0 Str.	1-7/16	2-1/4		4	
NDR6544T14		2 Sol. - 1000	3/8 - 3/4		550 - 700	750 - 1000	2 Sol. - 250	300 - 500	1-7/8	2-7/8		1/2	4-3/4
NDR65528T12		6 Sol. - 4/0 Str.	—	1	6 Sol. - 1 Str.	2/0 Sol. - 4/0 Str.			1-1/16	1-3/4		3/8	4-1/8
NDR65534T12	1-1/8-12	6 Sol. - 500	3/8 - 1/2	2	250 - 350	400 - 500	6 Sol. - 2 Str.	1/0 Sol. - 4/0 Str.	1-7/16	2-1/4	3/8	4	
NDR65544T12		2 Sol. - 1000	3/8 - 3/4		550 - 700	750 - 1000	2 Sol. - 250	300 - 500	1-7/8	2-7/8		1/2	4-5/8
NDR6644T12	1-1/4-12	2 Sol. - 1000	3/8 - 3/4		550 - 700	750 - 1000	2 Sol. - 250	300 - 500	1-7/8	2-7/8	1/2	4-5/8	
NDR6728T12	1-1/2-12	6 Sol. - 4/0 Str.	—	1	6 Sol. - 1 Str.	2/0 Sol. - 4/0 Str.			1-1/16	2-1/4	1/2	4-3/4	
NDR6734T12		6 Sol. - 500	3/8 - 1/2	2	250 - 350	400 - 500	6 Sol. - 2 Str.	1/0 Sol. - 4/0 Str.	1-7/16	2-3/8		3/8	5
NDR6744T12		2 Sol. - 1000	3/8 - 3/4		550 - 700	750 - 1000	2 Sol. - 250	300 - 500	1-7/8	2-7/8		1/2	5-1/8
NDR6748T12		4/0 Str. - 2000	3/8-1-1/4	1250 - 1600	1700 - 2000	4/0 Str. - 600	650 - 1200	2-3/8	3-1/4	5-3/4			
NDR6844T12	2-12	2 Sol. - 1000	3/8 - 3/4		550 - 700	750 - 1000	2 Sol. - 250	300 - 500	1-7/8	2-7/8	1/2	6-1/8	
NDR6848T12		4/0 Str. - 2000	3/8-1-1/4	1250 - 1600	1700 - 2000	4/0 Str. - 600	650 - 1200	2-3/8	3-1/4	6-5/8			

L-15

Blue highlighted items are industry standard and most frequently ordered.

**TYPE FD**

**STUD CONNECTOR**

For Stud to Flat Bar

High copper alloy stud connector allows bolting cable and tubing terminals to equipment studs. Hex head captured bolts provide one-wrench installation. One pad contact surface is on centerline of stud. Pad is finished on both sides. All pads are four hole NEMA drilled.

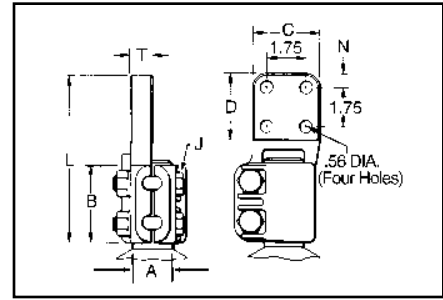
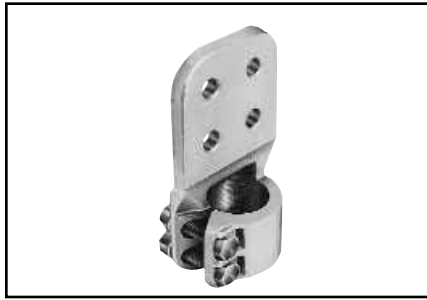

Catalog Number	Stud A	Nominal Ampere Rating ①	B	C	D	J	L	N	T
FD64C5T16	3/4"-16	1000	1.75	3.00	3.00	3/8"-16	5.72	.62	.31
FD65C6T14	1"-14	1075		3.00	3.00		5.72	.62	.38
FD65C6	1-1/8"-12	1075		3.00	3.00		5.80	.62	.38
FD65D6		1300		4.00	4.00		6.86	1.12	.38
FD66C6	1-1/4"-12	1075		3.00	3.00		5.78	.62	.38
FD66D6		1300		4.00	4.00		6.84	1.12	.38
FD67C6	1-1/2"-12	1075	2.18	3.00	3.00	1/2"-13	6.23	.62	.38
FD67D8		1450		4.00	4.00		7.30	1.12	.50
FD67C8	1-3/4"-12	1220		3.00	3.00		6.32	.62	.50
FD675D8		1450		4.00	4.00		7.39	1.12	.50
FD68C8	2"-12	1220		3.00	3.00		6.35	.62	.50
FD68D8		1450		4.00	4.00		7.42	1.12	.50
FD68D12	2-1/4"-12	2100	2.50	4.00	4.00	7.42	1.12	.75	
FD685C8		1220		3.00	3.00	6.71	.62	.50	
FD685D8		1450		4.00	4.00	7.77	1.12	.50	
FD685D12		2100		4.00	4.00	7.77	1.12	.75	
FD69C8		2-1/2"-12		1220	3.00	3.00	6.77	.62	.50
FD69D8				1450	4.00	4.00	8.03	1.12	.50
FD69D12	3"-12	2100	2.88	4.00	4.00	8.03	1.12	.75	
FD70D12		2100		4.00	4.00	8.26	1.12	.75	
FD70D16		3000		4.00	4.00	5/8"-11	8.24	1.12	1.00

**NOTES:**

- ① Indoor Rating
- 2. Contact factory for other variations in drilling, plating, etc.

Blue highlighted items are industry standard and most frequently ordered.



**TYPE QGFL**

**BARTAP™**

For Copper Cable to Flat

High copper alloy BARTAP™ for joining a range of cable to bar or pad. One-wrench installation.

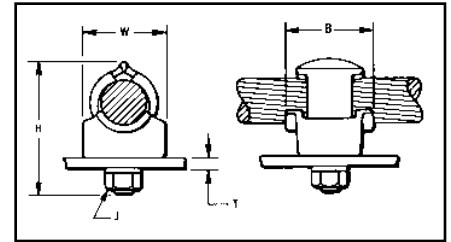
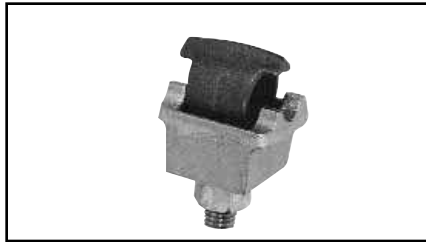

Catalog Number	Conductor	B	H	J	T (Max.)	W
<b>QGFL1CB1</b>	10 Sol. - 1 Str.	1-1/8	1-7/8	3/8	1/4	1
<b>QGFL1CB1T6</b>			2-3/8		3/4	
<b>QGFL26B1</b>	8 Sol. - 2/0 Str.	1-1/4	2-1/8	1/2	1/4	1-1/8
<b>QGFL26B1T6</b>			2-5/8		3/4	
<b>QGFL26B2*</b>			1-1/2		1/4	
<b>QGFL26B2T6*</b>			2-7/8		3/4	
<b>QGFL29B1*</b>	6 Str. - 250	1-5/8	2-5/8	1/2	1/4	1-3/8
<b>QGFL29B1T6*</b>			3-1/8		3/4	
<b>QGFL31B1*</b>	2 Sol. - 350	1-3/4	2-7/8	1/2	1/4	1-5/8
<b>QGFL31B1T6*</b>			3-1/4		3/4	
<b>QGFL34B1</b>	1/0 Sol. - 500	2	3-1/8	1/2	1/4	1-3/4
<b>QGFL34B1T6</b>			3-5/8		3/4	
<b>QGFL39B1</b>	350 - 750	2-1/4	3-1/4	1/2	1/4	1-3/4
<b>QGFL39B1T6</b>			3-5/8		3/4	
<b>QGFL44B1</b>	750 - 1000	2-1/4	3-3/8	1/2	1/4	2-1/8
<b>QGFL44B1T6</b>			4-1/8		3/4	
<b>QGFL46B1</b>	1000 - 1500	2-1/4	4	1/2	1/4	2-1/2
<b>QGFL46B1T6</b>			4-1/2		3/4	
<b>QGFL48B1</b>	1500 - 2000	2-1/4	4-3/4	1/2	1/4	3

\* Can be installed side by side or in-line on NEMA drilled bar.

**TYPE FCB**

**TRANSFORMER TAP ADAPTER**

For Copper and Aluminum

Cast in one piece from copper alloy. Transformer tap adapter designed to accommodate from 1 to 6 NEMA drilled copper or aluminum terminal taps from a single secondary transformer outlet. Tin-plated. Order mounting hardware and tap terminals separately.

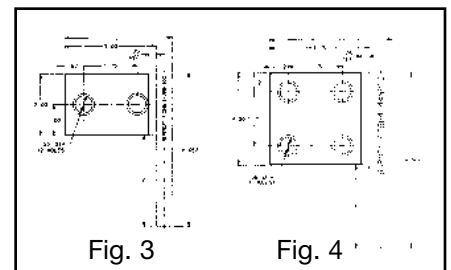
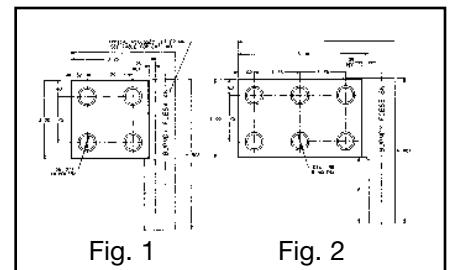
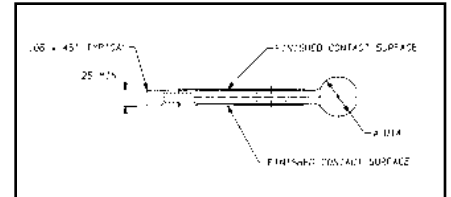
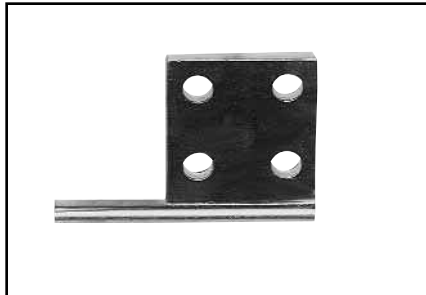

Fig. No.	Catalog Number	A Dia.	H REF	L	P
1	<b>FCB63-4N</b>	.50	5.25	3.75	2.25
2	<b>FCB63-6N</b>	.50	5.25	5.50	2.25
1	<b>FCB64-4N</b>	.75	5.75	4.00	2.75
2	<b>FCB64-6N</b>	.75	5.75	5.75	2.75
1	<b>FCB65-4N</b>	1.00	7.00	4.25	4.00
3	<b>FCB63-2NP300</b>	.50	5.00	3.50	3.00
4	<b>FCB64-44NP50</b>	.75	9.00	5.00	5.00

Blue highlighted items are industry standard and most frequently ordered.

**TYPE E-C-G**

**TRANSFORMER  
TAP ADAPTER**

For Copper Cable

Multi-tap, range-taking cast copper alloy connector designed to take 2, 3, or 4 conductors from a single secondary transformer outlet.

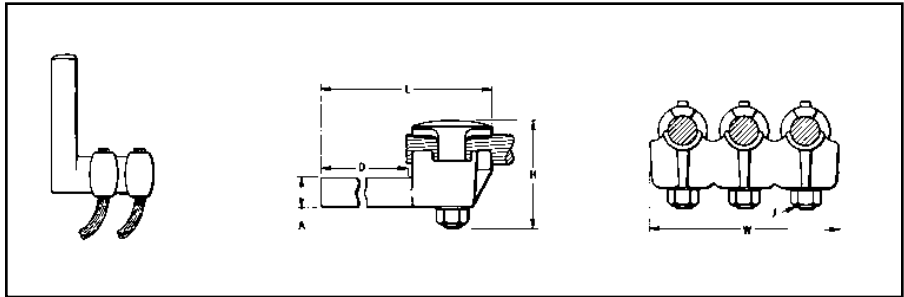
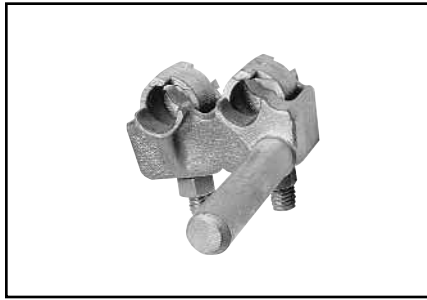

Catalog Number	Number of Conductors	Conductor Size	A Dia.	D	H	J	L	W
E2C34G1	2	1/0 Sol. to 500	.78	3-3/4	3-7/8	1/2-13	6-1/4	3-1/2
E3C34G1	3							5-1/4
E4C34G1	4							6-7/8

Blue highlighted items are industry standard and most frequently ordered.

**TYPE HFBW**

**BAR CLAMP**

For Copper Bar

The clamp assembly eliminates the need for drilling the flat bar and is used in indoor and outdoor applications.

The open web design provides a uniform clamping pressure while minimizing the weight of the connector.

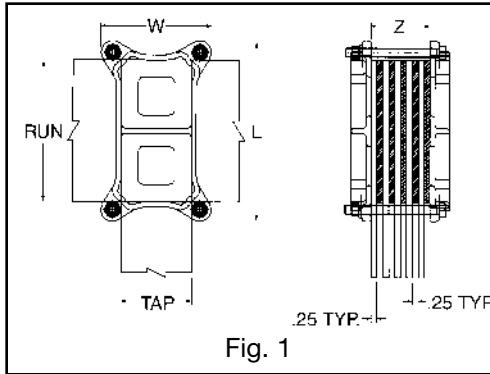
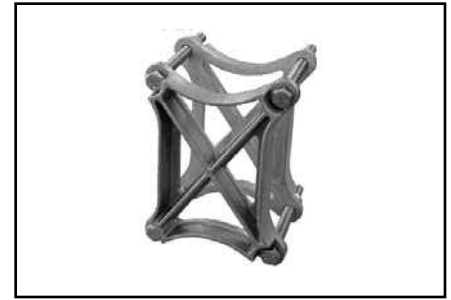
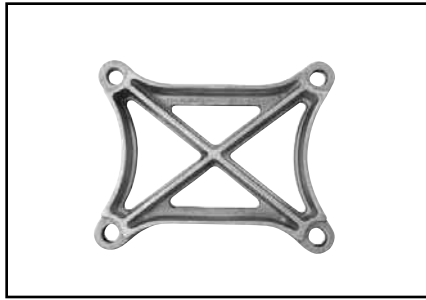

Fig. 1

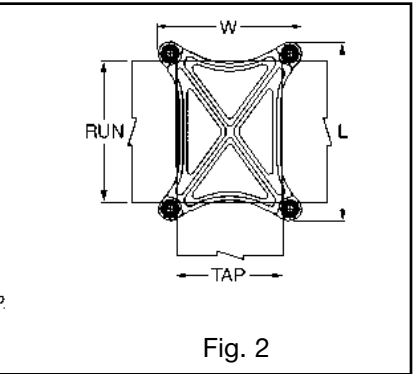

Fig. 2

**FEATURES**

- Web design cast copper body.
- Fully threaded yellow galvanized bolts with split-lockwashers and nuts included.
- Flat bar accommodation molded into body.

**BENEFITS**

- Increased torsional resistance.
- Reduced weight.
- Simple installation.
- Easy identification.

Catalog Number *	Conductor		Figure Number	Standard Maximum 'Z' Dimension	Total Number of Flat Bars (Standard 1/4" Thick)	Bolt Size	Dimensions	
	Run	Tap					W	L
HFBW86T20CG1	8.0	6.0	2	5.00	20	5/8"-11	8.13	10.13
HFBW66T16CG1	6.0	6.0	2	4.00	16	1/2"-13	7.75	7.75
HFBW64T17CG1	6.0	4.0	2	4.25	17	1/2"-13	5.75	7.75
HFBW44T17CG1	4.0	4.0	2	4.25	17	1/2"-13	5.68	5.68
HFBW43T10CG1	4.0	3.0	2	2.50	10	3/8"-16	4.42	5.42
HFBW42T10CG1	4.0	2.0	1	2.50	10	3/8"-16	3.54	5.55

\* Catalog number based on standard maximum "Z" dimension. Refer to your FCI representative for non-standard "Z" dimensions.  
Add TN suffix for tin plating (example: HFBW86T20CG1TN).  
All dimensions in inches.

L-19

Blue highlighted items are industry standard and most frequently ordered.

## TYPE HFB-P1

### BAR CLAMP ASSEMBLY COMPONENTS

For Copper Bar

To build your own high strength clamp assembly for multiple flat bar using type HFB-P1 bar clamps & clamping hardware, the following tables have been provided. The clamp assembly eliminates the need for drilling the flat bar and is used in indoor and outdoor applications.

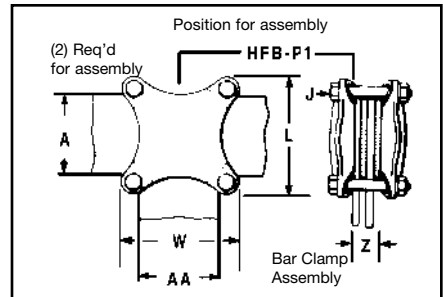

One Clamp Half					
Bar Clamp Catalog Number	Bus Bar		"J" Bolt Dia.	L	W
	Run 'A'	Tap 'AA'			
HFB33P1	3.00	3.00	3/8	4.38	4.38
HFB44P1	4.00	4.00	1/2	5.75	5.75
HFB63P1	6.00	3.00	1/2	7.75	4.75
HFB66P1	6.00	6.00	5/8	8.12	8.12
HFB88P1	8.00	8.00	3/4	10.50	10.50

Copper Bus Bar Width (Inches)		Bar Clamp Assembly Components †							
		Bar Clamp		Silicon Bronze Clamping Hardware					
				Bolts**		Nuts		Split Lockwashers	
Run-A	Tap-AA	Qty.	Cat. No.	Qty.	Cat. No.	Qty.	Cat. No.	Qty.	Cat. No.
3	3	2	HFB33P1	4	38 X (*) HEB	4	38CHEN	4	38SW
4	4	2	HFB44P1	4	50 X (*) HEB	4	50CHEN	4	50SW
6	3	2	HFB63P1	4	50 X (*) HEB	4	50CHEN	4	50SW
6	6	2	HFB66P1	4	62 X (*) HEB	4	62CHEN	4	62SW
8	8	2	HFB88P1	4	75 X (*) HEB	4	75CHEN	4	75SW

L-20

† Ordered separately from BURNDY®.

\* Z = Space between the bar clamp contact surfaces.

\*\*See table below when ordering assembly clamping bolts to specify correct bolt length in Cat. #.

Clamp Number	'J' Bolt Dia.	Bolt Length**							
		When Z=1.25*	When Z=1.50*	When Z=1.75*	When Z=2.00*	When Z=2.25*	When Z=2.50*	When Z=2.75*	When Z=3.00*
HFB33P1	3/8"(-16)	3.00	3.25	3.50	4.00	4.00	4.50	4.50	5.00
HFB44P1	1/2"(-13)	3.25	3.50	3.75	4.00	4.50	4.50	5.00	5.00
HFB63P1	1/2"(-13)	3.25	3.50	3.75	4.00	4.50	4.50	5.00	5.00
HFB66P1	5/8"(-11)	3.50	4.00	4.00	4.50	4.50	5.00	5.00	6.00
HFB88P1	3/4"(-10)	3.75	4.00	4.50	4.50	5.00	5.00	5.50	5.50

Blue highlighted items are industry standard and most frequently ordered.

**TYPE HFB-N**

**BAR CLAMP  
TAP PAD ADAPTER**

For Copper Bar

High conductivity copper, tap pad adapter provides a NEMA drilled contact pad when assembled to the HFB-P1 clamps. Tap connections can be made from copper bus bar(s) without drilling by bolting standard mechanical or compression terminal pads directly to the pre-drilled tap pad adapter.

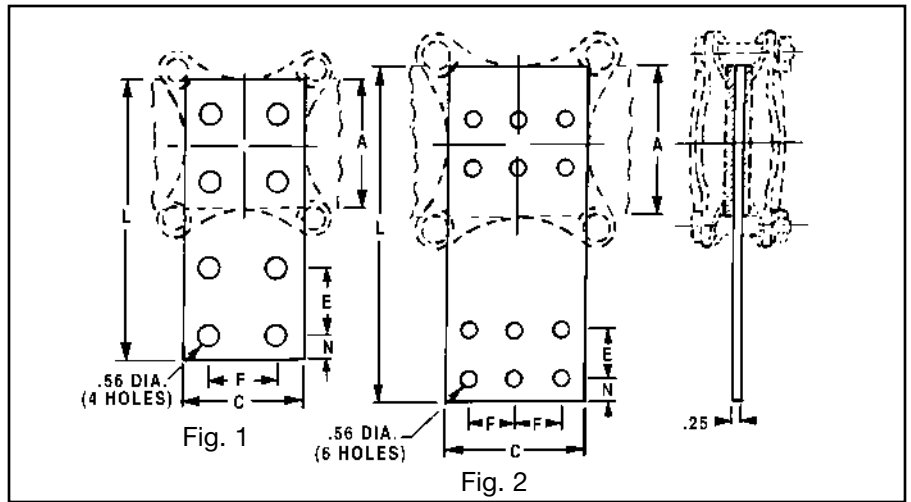
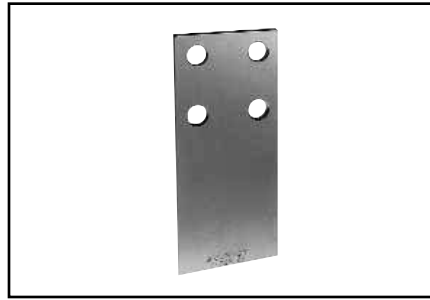

Catalog Number	Fig. No.	A-C	E & F	L	N	① Use With 'H' Clamp Cat. No.
HFB33-4N	1	3.00	1.75	7.00	.62	HFB33P1
HFB44-4N	1	4.00	1.75	9.12	1.12	HFB44P1
HFB66-6N	2	6.00	1.75	11.31	1.12	HFB66P1

① 'H' Clamp (two required per assembly) and hardware (as shown) not included with bar clamp tap pad, order separately.

L-21

**TYPE FN**

**CONTACT NUT**

Flat to Stud

High copper alloy contact nut for joining bar or terminal pads to studs. Designed to carry full current load from flat to stud.

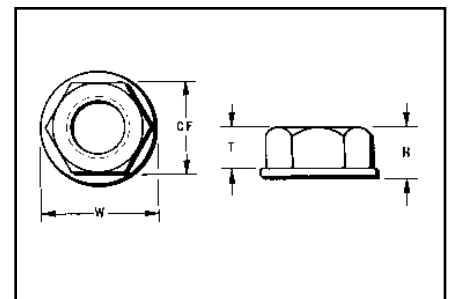

Catalog Number Type FN	Stud Dia. and Threads per Inch	CF (Cross Flats)	H	T	W
FN62T16	3/8 - 16	3/4	3/8	5/16	7/8
FN63T13	1/2 - 13	1	15/32	3/8	1-1/4
FN64T16	3/4 - 16	1-1/4	3/4	9/16	1-1/2
FN655T12	1-1/8 - 12	1-3/4	1	3/4	2-1/8
FN66T14	1-1/4 - 14	2	1-1/8	7/8	2-3/8
FN67T12	1-1/2 - 12	2-3/8			2-3/4

Blue highlighted items are industry standard and most frequently ordered.

## ALUMINUM INTRODUCTION

### CONNECTORS FOR ALUMINUM CONDUCTORS

Bolted aluminum connectors are cast of aluminum alloy and assembled with aluminum alloy bolts, nuts and galvanized steel washers. The hex head bolts are captured for one-wrench installation. The connectors accommodate aluminum or copper conductor. The “mass anode” design pioneered by BURNDY® minimizes the effect of galvanic corrosion on aluminum (anode+) connectors when used with copper (cathode -) conductor (Reference Fig. 1).

Joint deterioration caused by relaxation or “cold flow” of the aluminum is eliminated by the massive design. Generous contact areas distribute clamping forces evenly over the conductor, eliminating points of high stress that cause “cold flow.” These contact areas are factory treated to remove surface oxides and coated with an oxide inhibitor to prevent their reformation. Large radiating surfaces allow the connectors to run cooler than the copper conductor compensating for the fact that aluminum has a higher coefficient of thermal expansion. Connector and conductor expand and contract together during load cycles, eliminating stresses on the aluminum body that can cause relaxation of the joint.

### CONNECTOR SELECTION

Generally, copper connectors are recommended for copper conductor and aluminum connectors for aluminum conductor. Where aluminum connectors are recommended for use on both aluminum and copper conductors, the copper must be positioned parallel to or below the aluminum to prevent contamination of the aluminum by copper salts washed down by rain.

Except where indicated, all rigid connectors accept standard or extra heavy I.P.S. and all flexible connectors standard I.P.S. If extra heavy I.P.S. is to be used with a flexible joint, it must be spelled out at the time of ordering so that the proper cross sectional area of the flexible element may be supplied for the increased conductor rating.

### CONDUCTOR PREPARATION

To obtain optimum performance from any connector, the conductor surface must be thoroughly cleaned before installation. The surface oxides that form on all conductors act as insulation. Failure to remove them can result in high resistance joint and, ultimately, failure.

Conductor contact surfaces should be scratch brushed until bright and shiny. Aluminum conductor (new or old) should be coated with BURNDY® PENETROX™ after scratch brushing. PENETROX™ is a joint compound that aids in the establishment of low resistance joints and prevents aluminum oxides from reforming.

L-22

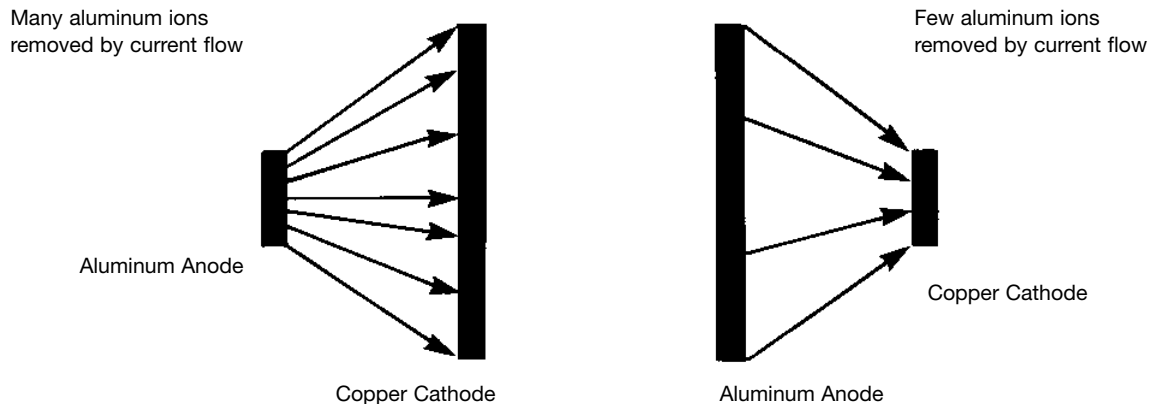

Fig. 1

Blue highlighted items are industry standard and most frequently ordered.

**TYPE NNT-A**

**T-CONNECTOR**

For Aluminum and Copper Tube to Tube

Aluminum alloy T-Connector for tubing run and tap. Properly proportioned to permit use on copper-aluminum conductor combinations. Captured hex head bolts permit one-wrench installation. PENETROX™ joint compound recommended on contact surfaces.

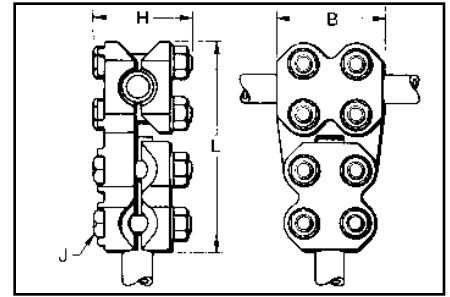
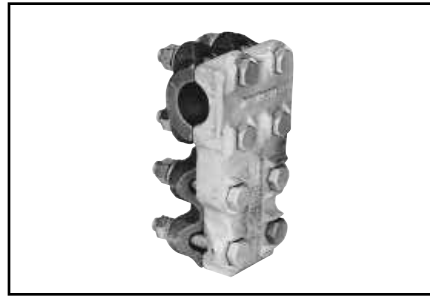

Catalog Number	Conductor		B	H	J	L
	Run	Tap				
NNT15A15A	1	1	3-1/2	3-3/8	1/2	6-7/8
NNT16A16A	1-1/4	1-1/4	3-3/4	3-3/8	1/2	7-1/2
NNT17A17A	1-1/2	1-1/2	4	3-7/8	1/2	7-7/8
NNT18A18A	2	2	4-1/4	4-1/2	5/8	9
NNT19A19A	2-1/2	2-1/2	4-1/2	5	5/8	9
NNT20A20A	3	3	5	5	5/8	11
NNT21A20A	3-1/2	3	5-1/2	5-5/8	5/8	11-5/8
NNT22A22A	4	4	6	6-1/4	5/8	12-5/8

**TYPE NNTR-A**

**T-CONNECTOR**

For Aluminum and Copper Tube to Cable

Aluminum alloy T-Connector for tube run, range of cable tap. Properly proportioned to permit use on copper-aluminum combinations. One-wrench installation. PENETROX™ joint compound recommended on contact surfaces.

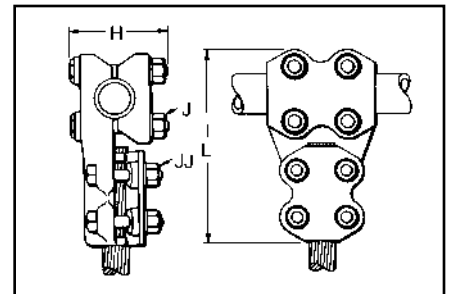

L-23

Catalog Number	Conductor			H	J	JJ	L
	Tap						
	Run	Alum. or Cu.	ACSR				
NNTR14A29A	3/4	1/0 Str. - 250	1/0 (6-1) - 4/0 (6-1)	3-1/8	1/2	1/2	5-7/8
NNTR14A36A	3/4	350 - 600	336.4 (18-1) - 477 (30-7)	3-1/8			6-3/8
NNTR15A36A	1	350 - 600	336.4 (18-1) - 477 (30-7)	3-3/8			6-5/8
NNTR15A42A	1	600 - 900	477 (30-7) - 795 (54-7)	3-3/8			6-7/8
NNTR16A29A	1-1/4	1/0 Str. - 250	1/0 (6-1) - 4/0 (6-1)	3-3-7/8			6-1/2
NNTR16A32A	1-1/4	250 - 400	4/0 (6-1) - 397.5 (18-1)	3-3/8			6-3/4
NNTR16A42A	1-1/4	600 - 900	477 (30-7) - 795 (54-7)	3-7/8			7-1/4
NNTR17A29A	1-1/2	1/0 Str. - 250	1/0 (6-1) - 4/0 (6-1)	3-7/8			6-3/4
NNTR18A29A	2	1/0 Str. - 250	1/0 (6-1) - 4/0 (6-1)	4-1/2			7-5/8
NNTR19A42A	2-1/2	600 - 900	477 (30-7) - 795 (54-7)	4-5/8			8-7/8
NNTR20A32A	3	250 - 400	4/0 (6-1) - 397.5 (18-1)	5			9
NNTR22A46A	4	1250 - 1600	1113 (54-9) - 1431 (45-7)				9-1/4

Blue highlighted items are industry standard and most frequently ordered.

## TYPE NNTR-A

### T-CONNECTOR

For Aluminum and Copper Cable to Cable

Aluminum alloy T-Connector for a range of copper, aluminum and ACSR cable on run and tap. Properly proportioned to permit use on copper-aluminum conductor combinations. One-wrench installation. PENETROX™ joint compound recommended on contact surfaces.

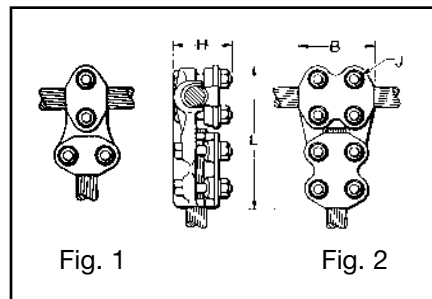

Catalog Number	Conductor				Fig. No.	B	H	J	L
	Run		Tap						
	Alum. or Copper	ACSR	Alum. or Copper	ACSR					
NNTR29A29A	1/0 Str. - 250	1/0 (6-1) - 4/0 (6-1)	1/0 Str. - 250	1/0 (6-1) - 4/0 (6-1)	2	2-3/4	2-5/8	1/2	5-5/8
NNTR32A25A	250 - 400	4/0 (6-1) - 397.5 (18.1)	4 Str. - 1/0 Str.	4 (6-1) - 1/0 (6-1)	1	1-7/8	2-5/8		4-7/8
NNTR32A32A	250 - 400	4/0 (6-1) - 397.5 (18-1)	250 - 400	4/0 (6-1) - 397.5 (18-1)	2	3	2-5/8		6
NNTR36A29A	350 - 600	336.4 (18-1) - 477 (30-7)	1/0 Str. - 250	1/0 (6-1) - 4/0 (6-1)	2	3-1/4	2-5/8		5-7/8
NNTR36A36A	350 - 600	336.4 (18-1) - 477 (30-7)	350 - 600	336.4 (18-1) - 477 (30-7)	2	3-1/4	2-5/8		6-3/8
NNTR42A32A	600 - 900	477 (30-7) - 795 (54-7)	250 - 400	4/0 (6-1) - 397.5 (18-1)	2	3-1/2	3-1/8		6-3/8
NNTR42A36A	600 - 900	477 (30-7) - 795 (54-7)	350 - 600	336.4 (18-1) - 477 (30-7)	2	3-1/2	3-1/8		6-5/8
NNTR42A42A	600 - 900	477 (30-7) - 795 (54-7)	600 - 900	477 (30-7) - 795 (54-7)	2	3-1/2	3-1/8		6-7/8
NNTR45A45A	900 - 1250	715.5 (30-19) - 1113 (54-19)	900 - 1250	715.5 (30-19) - 1113 (54-19)	2	3-3/4	3-1/4		7-3/8
NNTR46A42A	1250 - 1600	1113 (54-19) - 1431 (45-7)	600 - 900	477 (30-7) - 795 (54-7)	2	3-3/4	3-1/2		7-1/4
NNTR46A46A	1250 - 1600	1113 (54-19) - 1431 (45-7)	1250 - 1600	1113 (54-19) - 1431 (45-7)	2	4-3/8	3-3/4	5/8	8-3/8
NNTR48A48A	1500 - 2000	1272 (54-19) - 1780 (84-19)	1500 - 2000	1272 (54-19) - 1780 (84-19)	2	4-3/8	3-7/8	5/8	8-5/8

L-24

## TYPE NS-A

### COUPLER

For Aluminum and Copper Tube to Tube

Aluminum alloy coupler for joining equal sizes of tube end to end. Properly proportioned to permit use on aluminum-copper conductor combinations. One-wrench installation. PENETROX™ joint compound recommended on contact surfaces.

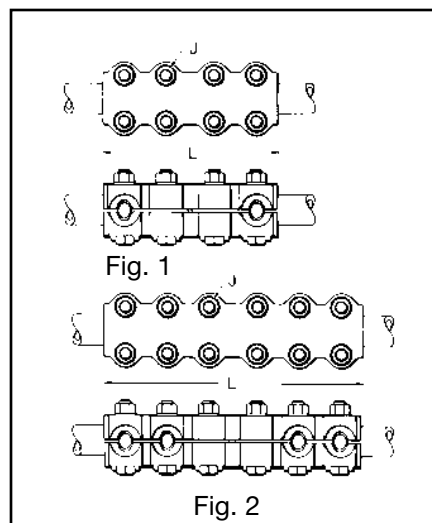
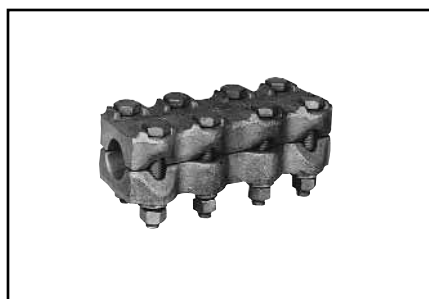

Catalog Number	Conductor I.P.S.	Fig. No.	J	L
NS14A14A	3/4	1	1/2	6-3/4
NS15A15A	1			7-1/4
NS17A17A	1-1/2			8-1/4
NS18A18A	2			8-3/4
NS19A19A	2-1/2		5/8	9-1/4
NS20A20A	3			10-1/4
NS21A21A	3-1/2			11-1/4
NS22A22A	4			12-1/4
NS24A24A	5	2		14-1/4

Blue highlighted items are industry standard and most frequently ordered.



## TYPE NA-A

### TERMINAL

For Aluminum and Copper Tube to Flat

Aluminum alloy terminal for joining copper or aluminum tube to copper or aluminum pad. Properly proportioned to minimize conductor corrosion due to galvanic action. Drilling in pad conforms to NEMA standards. One-wrench installation. PENETROX™ joint compound recommended on contact surfaces.

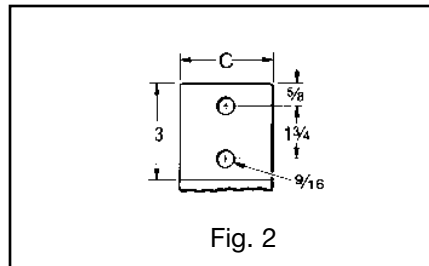

Fig. 2

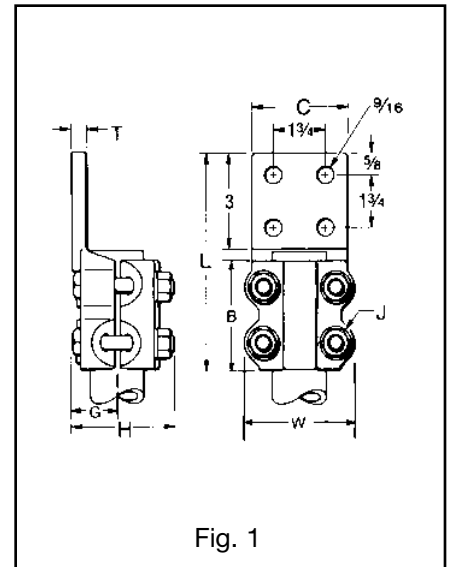

Fig. 1

Catalog Number	Conductor	Fig. No.	B	C	G	H	J	L	T	W
NA15A-2N	1	2	3-1/2	1-7/8	1.50	3-3/8	1/2	6-3/4	3/8	3-1/16
NA15A-4N	1	1	3-1/2	3	1.50	3-3/8	1/2	6-3/4	3/8	3-1/16
NA16A-4N	1-1/4	1	3-3/4	3	1.60	3-3/8	1/2	7	1/2	3-7/16
NA17A-2N	1-1/2	2	4	2-1/2	1.76	3-7/8	1/2	7-1/2	1/2	3-11/16
NA17A-4N	1-1/2	1	4	3	1.76	3-7/8	1/2	7-1/2	1/2	3-11/16
NA18A-2N	2	2	4-1/4	2-3/4	2.05	4-1/2	5/8	7-1/2	1/2	4-1/2
NA18A-4N	2	1	4-1/4	3-1/8	2.05	4-1/2	5/8	7-1/2	1/2	4-1/2
NA19A-4N	2-1/2	1	4-1/2	3-3/4	2.19	5	5/8	7-3/4	3/4	5
NA20A-4N	3	1	5	4-3/8	2.43	5-1/2	5/8	8-3/8	3/4	5-5/8
NA22A-4N	4	1	6	5-1/4	2.94	6-1/4	5/8	9-3/8	7/8	6-5/8

L-25

## TYPE XA-A

### EXPANSION TERMINAL

For Aluminum and Copper Tube to Flat

Aluminum alloy expansion connector for joining tube to copper or aluminum bar or equipment pads. Flexible aluminum straps allow longitudinal or lateral movement and carries full current load of the joint. PENETROX™ joint compound recommended on contact surfaces. Pad contact surface is on centerline of conductor.

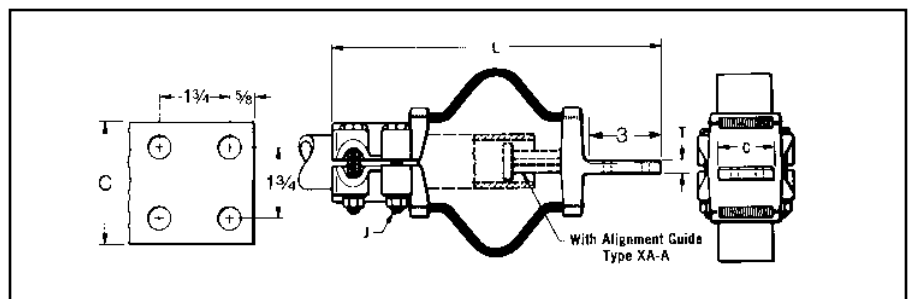

Catalog Number* Standard I.P.S. (Schedule 40) With Guide	Conductor	C	J	L	T
XA15A-4N	1	3	1/2	12-3/4	3/8
XA16A-4N	1-1/4	3		13-5/8	1/2
XA18A-4N	2	3		15-1/2	1/2
XA19A-4N	2-1/2	3-3/4	5/8	17	5/8
XA20A-4N	3	4-3/8		18-5/8	5/8
XA21A-4N	3-1/2	4-3/4		20	7/8
XA22A-4N	4	5-1/4		21	7/8
XA24A-4N	5	6-1/2		24-1/8	7/8

\* Conforms to 4-hole NEMA mounting standards.

Blue highlighted items are industry standard and most frequently ordered.

**TYPE NBC-A**

**BARTAP™**

Aluminum alloy bolted type terminal for joining aluminum tube to copper or aluminum pads. Drilling in pad conforms to NEMA Standards. PENETROX™ joint compound recommended on contact surfaces.

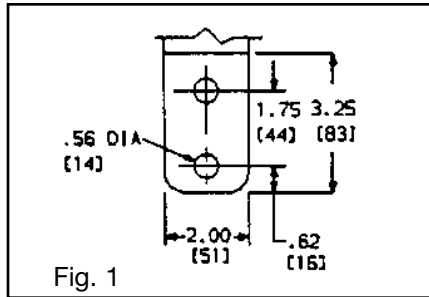
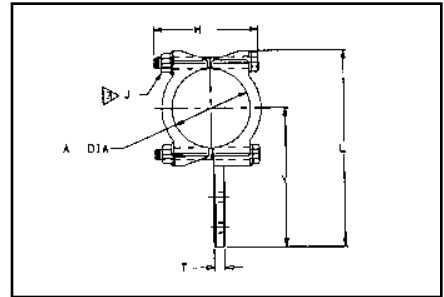
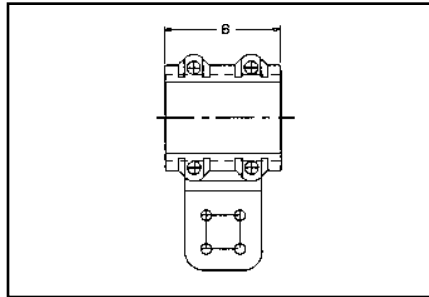

Fig. 1

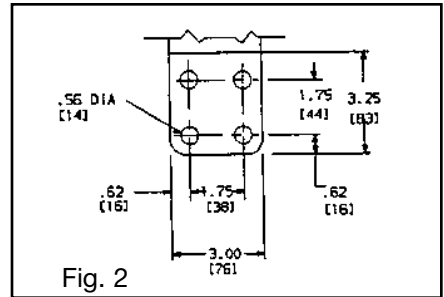

Fig. 2

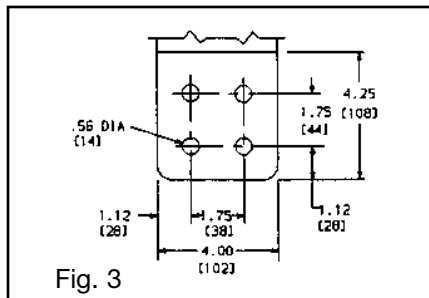

Fig. 3

L-26

Blue highlighted items are industry standard and most frequently ordered.

**TYPE NBC-A**

(Continued)

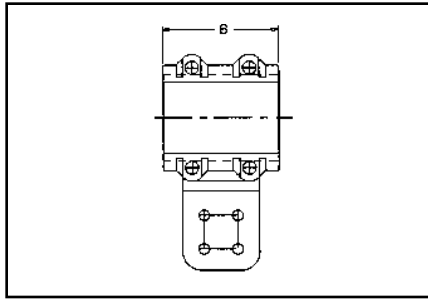

Conductor Aluminum		Catalog Number	Fig. No.	Dimensions In. [mm]					
IPS/EHPS	A			B	H	J	L	T	Y
1"	1.32 [33]	NBC15A-2N	1	3.50	3.00	1/2 - 13	6.81	.38	5.28
		NBC15A-34N	2	[89]	[76]		[173]	[10]	[134]
1-1/4"	1.66 [42]	NBC16A-2N	1	3.75	3.25	1/2 - 13	7.15	.38	5.45
		NBC16A-34N	2	[95]	[76]		[182]	[10]	[138]
		NBC16A-44N	3	3.75	3.25		8.15	.38	6.45
				[95]	[76]		[207]	[10]	[164]
1-1/2"	1.90 [48]	NBC17A-2N	1	4.00	3.50	1/2 - 13	7.39	.38	5.57
		NBC17A-34N	2	4.00	3.50		7.39	.38	5.57
		NBC17A-44N	3	4.00	3.50		8.39	.38	6.57
				[102]	[89]		[188]	[10]	[141]
2"	2.38 [42]	NBC18A-2N	1	4.25	4.00	5/8 - 11	8.25	.38	6.00
		NBC18A-34N	2	4.25	4.00		8.25	.38	6.00
		NBC18A-44N	3	4.25	4.00		9.25	.38	7.00
				[108]	[76]		[210]	[10]	[152]
2-1/2"	2.88 [73]	NBC19A-34N	2	4.50	4.50	5/8 - 11	8.75	.50	6.25
		NBC19A-44N	3	4.50	4.50		9.75	.50	7.25
				[114]	[114]		[222]	[13]	[159]
3"	3.00 [76]	NBC20A-34N	2	5.00	4.50	5/8 - 11	9.37	.50	6.56
		NBC20A-44N	3	5.00	4.50		10.37	.50	7.56
				[127]	[114]		[238]	[13]	[167]
3-1/2"	4.50 [33]	NBC21A-44N	3	5.50	5.00	5/8 - 11	10.89	.62	7.82
				[140]	[127]		[277]	[16]	[199]
4"	4.50 [114]	NBC22A-34N	2	6.00	5.50	5/8 - 11	10.37	.62	7.06
		NBC22A-44N	3	6.00	5.50		11.37	.62	8.06
				[152]	[140]		[263]	[16]	[179]
5"	5.56 [141]	NBC24A-34N	2	7.00	6.00	5/8 - 11	12.45	.62	8.60
				[178]	[152]		[316]	[16]	[218]
6"	6.62 [168]	NBC86A-44N	3	8.00	7.25	5/8 - 11	13.51	.75	9.13
				[203]	[184]		[343]	[19]	[232]

**NOTES:**

- Materials:  
Connector: Cast Aluminum Alloy  
Hardware: Aluminum Alloy
- Scratch brush connector contact, surface dry then apply an oxide inhibitor, "PENETROX™ A". "PENETROX™ A" can be purchased from BURNDY® in cans or plastic squeeze bottles.

- Recommended Tightening Torque:  
1/2-13 300 Inch Pounds  
5/8-11 480 Inch Pounds
- All dimensions in brackets [ ] are in millimeters.

Blue highlighted items are industry standard and most frequently ordered.

## TYPE NAR-A

### TERMINAL

For Aluminum and Copper Cable to Flat

Aluminum alloy terminal for joining a wide range of copper or aluminum cable to copper or aluminum pad. Properly proportioned to minimize conductor corrosion due to galvanic action. Drilling in pad conforms to NEMA standards. One-wrench installation. PENETROX™ A joint compound recommended on contact surfaces.

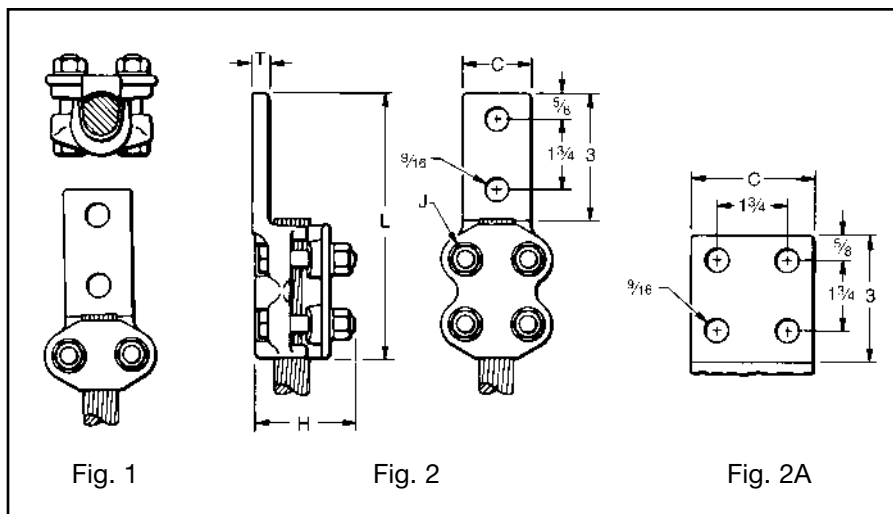

L-28

Catalog Number	Conductor		No. of Holes in Pad	Fig. No.	C	H	J	L	T	
	Alum. or Copper	ACSR								
NAR25A-2N	4 Str. - 1/0 Str.	4 (6-1) - 1/0 (6-1)	2 NEMA	1	1-1/4	2-3/8	1/2	5-1/4	5/16	
NAR29A-2N*	1/0 Str. - 250	1.0 (6-1) - 4/0 (6-1)		2	1-5/8	2-7/8				
NAR29A-4N*			4 NEMA	2A	3	2-3/4				
NAR32A-2N	250 - 400	4/0 (6-1) - 397.5 (18-1)	2 NEMA	2	1-5/8	2-7/8		6-3/8		3/8
NAR32A-4N			4 NEMA	2A	3					
NAR36A-2N	350 - 600	336.4 (18-1) - 477 (30-7)	2 NEMA	2	1-3/4	3-3/8	6-5/8	1/2		
NAR36A-4N*			4 NEMA	2A	3					
NAR42A-2N**	600 - 900	477 (30-7) - 795 (54-7)	2 NEMA	2	2		6-7/8		7-1/8	
NAR42A-4N*			4 NEMA	2A	3					
NAR45A-2N	900 - 1250	715 (30-19) - 1113 (54-19)	2 NEMA	2	2-5/8	3-3/4	7-3/4	5/8		
NAR45A-4N			4 NEMA	2A	3					
NAR46A-2N	1250 - 1600	1113 (54-19) - 1431 (54-7)	2 NEMA	2	2-3/4				7-7/8	3/4
NAR46A-4N*			4 NEMA	2A	3					
NAR48A-2N	1500 - 2000	1272 (54-19) - 1780 (84-19)	2 NEMA	2	2-3/4	4	7-7/8	3/4		
NAR48A-4N			4 NEMA	2A	3					

\* Available with 90 degree pad as shown (example: NAR36A-4N90).

\*\* Available with 45 degree pad as shown (example: NAR42A-2N45).

Blue highlighted items are industry standard and most frequently ordered.

**TYPE UHG-A**

**BUS SUPPORT**

For Aluminum and Copper Tube

Aluminum alloy bus support for mounting tube on post or pedestal insulators. Properly proportioned to minimize conductor corrosion due to galvanic action. Rotate caps 180° for slip or rigid fit. One-wrench installation. Supplied with hardware for mounting to cap of insulator. Specify base mounting hardware, if required, by adding suffix “-B”

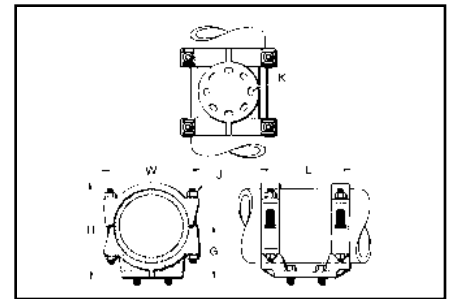

to Catalog Number. For static clips add “-CH” to Catalog Number.

Catalog Number	Conductor	Bolt Circle	G	H	J	K	L	W
UHG14A-3	3/4	3	2	3-1/2	1/2	9/16	7-1/2	3
UHG15A-3	1	3	2	3-5/8		9/16	7-1/2	3-1/8
UHG15A-5		5	2-1/4			11/16	9-7/8	
UHG17A-3	1-1/2	3	2-1/2	4-1/8		9/16	7-3/4	3-3/4
UHG17A-5		5				11/16	10-1/8	
UHG18A-3	2	3	2-3/4	5-1/4		9/16	7-3/4	4-1/8
UHG18A-5		5		4-5/8		11/16	10-1/8	
UHG19A-3	2-1/2	3	3-1/8	5-1/4		9/16	7-3/4	4-5/8
UHG20A-3	3	3	3-5/8	6-1/8		9/16	8-1/4	5-5/8
UHG20A-5		5				11/16	10-5/8	
UHG21A-3	3-1/2	3	4	6-3/4	5/8	9/16	8-1/4	6-1/4
UHG22A-5	4	5	4-1/2	7-1/2		11/16	10-5/8	6-5/8
UHG24A-3	5	3	5-1/4	8-7/8		9/16	8-3/4	7-3/4
UHG24A-5		5				11/16	11-5/8	

**TYPE UHKR-A**

**BUS SUPPORT**

For Aluminum Cable or Tube

Aluminum alloy bus support for mounting a wide range of cable or tube on post or pedestal type insulators. Supplied with hardware for mounting to cap of insulator. Specify base mounting hardware, if required, by adding suffix “-B” to Catalog Number.

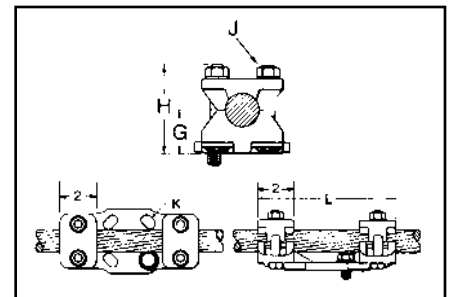

L-29

Catalog Number	Conductor			Bolt Circle	G *	H	J	K	L
	Aluminum	ACSR	Tube Sch. 40/80						
UHKR11A-3	4 Sol. - 4/0 Str.	6 (6-1) - 4/0 (6-1)	1/4	3	1-1/8	2-5/8	1/2	9/16	7-5/8
UHKR11A-5				5				11/16	9-1/2
UHKR13A-3	250 - 550	266.8 (6-7) - 477 (30-7)	3/8 - 1/2	3	1-3/8	2-7/8		9/16	7-5/8
UHKR13A-5				5				11/16	8-7/8
UHKR14A-3	600 - 1113	556.5 (26-7) - 1033.5 (54-7)	3/4	3	1-3/4	3-5/8		9/16	7-5/8
UHKR14A-5				5				1-1/2	3-3/8
UHKR16A-3	1000 - 2000	1113 (54-19) - 1780 (84-19)	1 - 1-1/4	3	1-31/32	4-1/16	1/2	9/16	7-9/16
UHKR16A-5				5				1-13/16	3-7/8

\* With maximum conductor in place.

Blue highlighted items are industry standard and most frequently ordered.

**TYPE LB-A**

**END CAP**

Aluminum alloy end cap for aluminum tube. Driven into place for a secure fit. Seals out moisture, reduces electrostatic loss and eliminates hazards created by nesting birds.

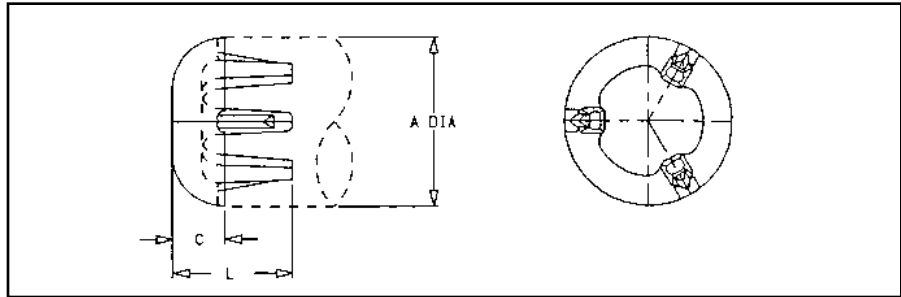

Conductor Aluminum Pipe Size	Dimensions In./[mm]			Catalog Number	
	A	C	L	Schd. 40	Schd. 80
1/2"	.84 [21]	.38 [9.7]	1.25 [32]	LB13A	LB53A
3/4"	1.05 [27]	.50 [13]	1.37 [35]	LB14A	LB54A
1"	1.32 [34]	.50 [13]	1.43 [36]	LB15A	LB55A
1-1/4"	1.66 [42]	.50 [13]	1.43 [36]	LB16A	LB56A
1-1/2"	1.90 [48]	.50 [13]	1.45 [37]	LB17A	LB57A
2"	2.38 [60]	.88 [22]	1.85 [47]	LB18A	LB58A
2-1/2"	2.88 [73]	.88 [22]	2.01 [51]	LB19A	LB59A
3"	3.50 [89]	.88 [22]	2.10 [53]	LB20A	LB90A
3-1/2"	4.00 [102]	.88 [22]	2.15 [55]	LB21A	LB91A
4"	4.50 [114]	.88 [22]	2.22 [56]	LB22A	LB92A
5"	5.56 [141]	.88 [22]	2.34 [59]	LB24A	LB94A
6"	6.63 [168]	.88 [22]	2.46 [62]	LB86A	LB96A

**NOTES:**

1. Material: Cast Aluminum Alloy.
2. Dimensions in brackets [ ] are in millimeters.

L-30

Blue highlighted items are industry standard and most frequently ordered.

**TYPE WAS-A**

**TERMINAL CONNECTOR**

Aluminum alloy weld type terminal for joining aluminum tube to copper or aluminum pads. Drilling in pad conforms to NEMA standards. PENETROX™ joint compound recommended on pad contact surfaces.

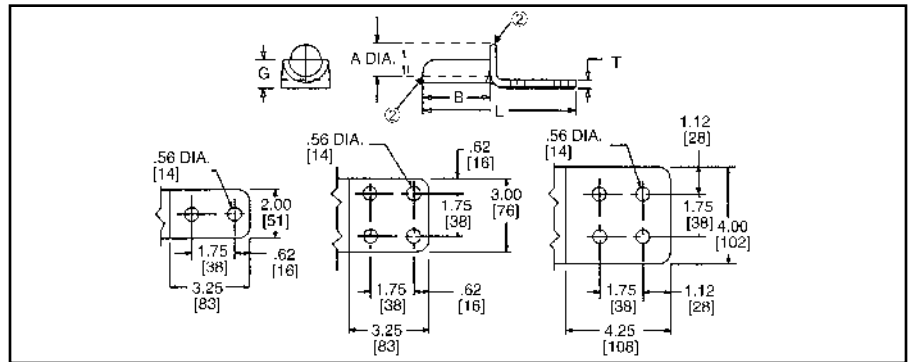

Conductor Aluminum		Catalog Number	Dimensions In./[mm]			
Sch. 40/Sch. 80	A		B	G	L	T
3/4"	1.05 [27]	WAS14A-2N	2.50 [64]	1.50 [38]	6.50 [165]	.38 [9.7]
1"	1.32 [34]	WAS15A-2N	2.75 [70]	1.19 [30]	6.75 [171]	.38 [9.7]
		WAS15A-34N	2.75 [70]	1.19 [30]	6.75 [171]	.38 [9.7]
1-1/4"	1.66 [42]	WAS16A-2N	3.00 [76]	1.38 [35]	7.00 [178]	.38 [9.7]
		WAS16A-34N	3.00 [76]	1.38 [35]	7.00 [178]	.38 [9.7]
1-1/2"	1.90 [48]	WAS17A-2N	3.25 [83]	1.50 [38]	7.25 [184]	.44 [11]
		WAS17A-34N	3.25 [83]	1.50 [38]	7.25 [184]	.38 [9.7]
2"	2.38 [60]	WAS18A-2N	3.50 [89]	1.75 [44]	7.50 [191]	.44 [11]
		WAS18A-34N	3.50 [89]	1.75 [44]	7.50 [191]	.38 [9.7]
		WAS18A-44N	3.63 [92]	1.75 [44]	8.62 [219]	.50 [12.7]
2-1/2"	2.88 [73]	WAS19A-2N	3.63 [92]	2.00 [51]	7.87 [200]	.56 [14.2]
		WAS19A-34N	3.63 [92]	2.00 [51]	7.87 [200]	.56 [14.2]
		WAS19A-44N	3.63 [92]	2.00 [51]	8.87 [225]	.50 [12.7]
3"	3.50 [89]	WAS20A-2N	3.67 [93]	2.38 [60]	8.25 [210]	.69 [17.5]
		WAS20A-34N	3.75 [95]	2.38 [60]	8.25 [210]	.62 [15.7]
		WAS20A-44N	3.75 [95]	2.38 [60]	9.25 [235]	.62 [15.7]
3-1/2"	4.00 [102]	WAS21A-34N	4.25 [108]	2.62 [67]	8.50 [216]	.62 [15.7]
		WAS21A-44N	4.25 [108]	2.62 [67]	9.50 [241]	.62 [15.7]
4"	4.50 [114]	WAS22A-44N	4.25 [108]	2.88 [73]	9.50 [241]	.75 [19.0]
5"	5.56 [141]	WAS24A-44N	4.25 [108]	3.62 [92]	9.50 [241]	.75 [19.0]
6"	6.63 [168]	WAS86A-44N	4.25 [108]	4.00 [102]	9.75 [248]	1.00 [25.4]

**NOTES:**

- 1 Material: Cast Aluminum Alloy.
- 2 WELDING TO BE DONE BY THE CUSTOMER. For welding recommendation see drawing SD73608

- 3 After welding, scratch brush connector contact surface dry then apply an oxide inhibitor "PENETROX™ A". "PENETROX™ A" can be purchased from BURNDY® in cans or plastic squeeze bottles.

- 4 Dimensions in brackets [ ] are in millimeters.
- 5 Tongue finished on ONE SIDE ONLY (bottom). For tongue finished on both sides, add suffix letter "Q" to Catalog Number (example: WAS22A-44NQ).

## TYPE WASC-A-N

### CENTERFORMED WELDMENT TERMINAL

Aluminum alloy weldment terminal. Type WASC-A-N has one contact surface on the center line of the tube. Holes are NEMA spaced for terminating aluminum or copper mating pads. PENETROX™ joint compound recommended for use on contact surfaces.

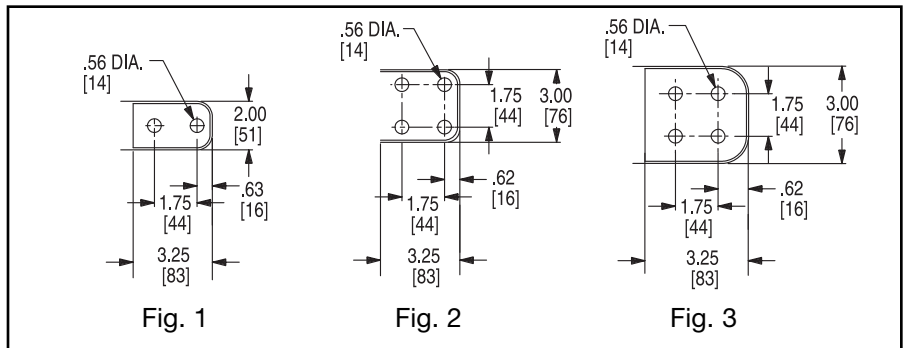
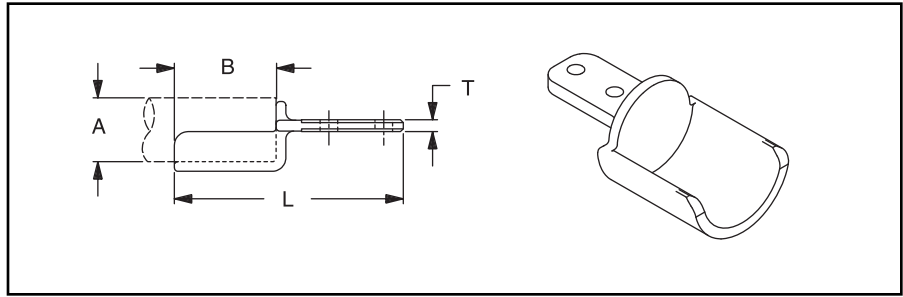

Catalog Number	Aluminum Conductor		Fig. No.	Dimensions Inches/[mm]		
	Schedule 40/80	A [mm]		B	L	T
WASC14A2N	3/4"	1.05 [27]	1	2.50 [64]	6.44 [164]	.22 [6]
WASC15A2N	1"	1.32 [33]	1	2.75 [70]	6.69 [170]	.38 [10]
WASC15A34N			2			
WASC16A2N	1-1/4"	1.66 [42]	1	3.00 [76]	7.00 [178]	.38 [10]
WASC16A34N			2			
WASC17A34N	1-1/2"	1.90 [48]	2	3.25 [83]	7.31 [186]	.44 [11]
WASC18A34N	2"	2.38 [60]	2	3.50 [90]	7.56 [192]	.50 [13]
WASC18A44N			3		8.56 [217]	
WASC19A2N	2-1/2"	2.88 [73]	1	3.75 [95]	7.88 [200]	.56 [14]
WASC19A34N			2		8.88 [226]	
WASC19A44N			3			
WASC20A2N	3"	3.50 [89]	1	4.00 [102]	8.13 [207]	.62 [16]
WASC20A34N			2		9.13 [232]	
WASC20A44N			3			
WASC21A2N	3-1/2"	4.00 [102]	1	4.25 [108]	8.38 [213]	
WASC21A34N			2		9.38 [238]	
WASC21A44N			3			
WASC22A2N	4"	4.50 [114]	1	4.25 [108]	8.38 [213]	.75 [19]
WASC22A34N			2		9.38 [238]	
WASC22A44N			3			
WASC24A34N	5"	5.56 [141]	2	4.25 [108]	8.50 [216]	.75 [19]
WASC24A44N			3		9.50 [241]	
WASC86A44N	6"	6.63 [168]	3	4.25 [108]	9.50 [241]	1.00 [25]

For tongue finished on both sides add suffix letter "Q" to Catalog Number (example: WASC14A2NQ).

Blue highlighted items are industry standard and most frequently ordered.



**TYPE WG-A**

**WELDMENT GROUND STUD**

Range-taking weldment stud for grounding Aluminum tube.

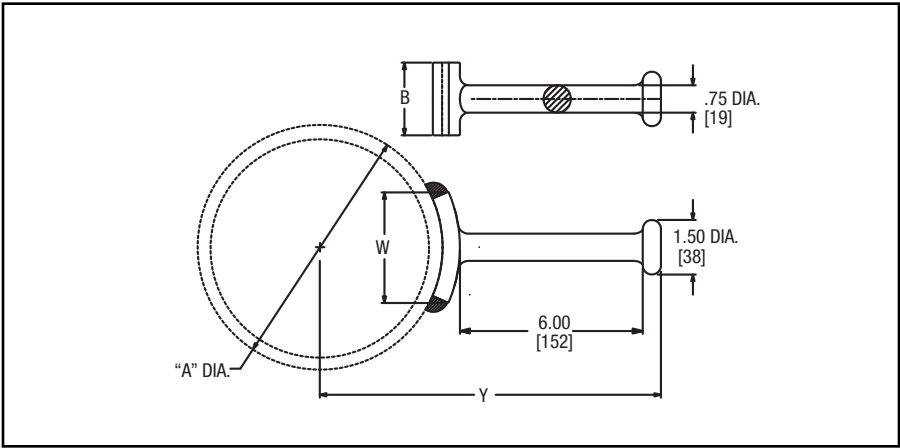

Catalog Number	Aluminum IPS	Dimensions Inches/[mm]			
		A	B	W	Y
<b>WG19A</b>	1" - 2-1/2"	1.315 - 2.88 [33] - [73]	3.00 [76]	1.32 [34]	8.19 [208]
<b>WG86A</b>	3" - 6"	3.50 - 6.62 [89] - [168]	2.00 [51]	3.06 [78]	10.31 [262]

Dimensions in brackets [ ] are in millimeters

Blue highlighted items are industry standard and most frequently ordered.