

Subject: Smart grid loop scheme

G&W Products: Lazer automation solution including five Viper-ST reclosers with SEL 651R controls and a SEL 3351 central processor.

Issue:

A major midwest utility has been focusing on automation to help assure reliable power to its customers. For years they have incorporated a SCADA system for transmission line and distribution substation monitoring. As a further enhancement, the utility decided to start building Smart Grids for their network loop locations. In a recent project, the utility chose a remote rural loop location which was experiencing frequent outages. These outages were attributed to the overhead power lines running close to mature trees where broken branches resulting from wind, rain, snow and ice were a major nuisance. Sending repair crews to these remote locations took longer than desired. The utility decided to automate the loop to create a Fault Detection, Isolation, and Restoration (FDIR) scheme. The scheme would need to be self-sufficient and able to provide data to the main SCADA system several states away. It also required a maximum reconfigure time of 90 seconds.

Solution:

After investigating the latest technology in automation, the utility selected G&W's pre-engineered Lazer solution utilizing G&W Viper-ST reclosers with Schweitzer Engineering, model SEL 651R, controls and one SEL 3351 central processor. The 3351 was used to automatically reconfigure the recloser controls as needed to maximize the efficiency of isolating a faulted section.



Viper-ST recloser with SEL 651R control.



The 3351 was located at the feeder substation so it could be easily interfaced with the utility SCADA network.

Five reclosers were placed at specific points in the loop to protect particularly troubled sections. Four of the Viper-ST's were configured as normally closed while the fifth was configured as a normally open point (see diagram). Along with the internal voltage sensing of the Viper-ST, all

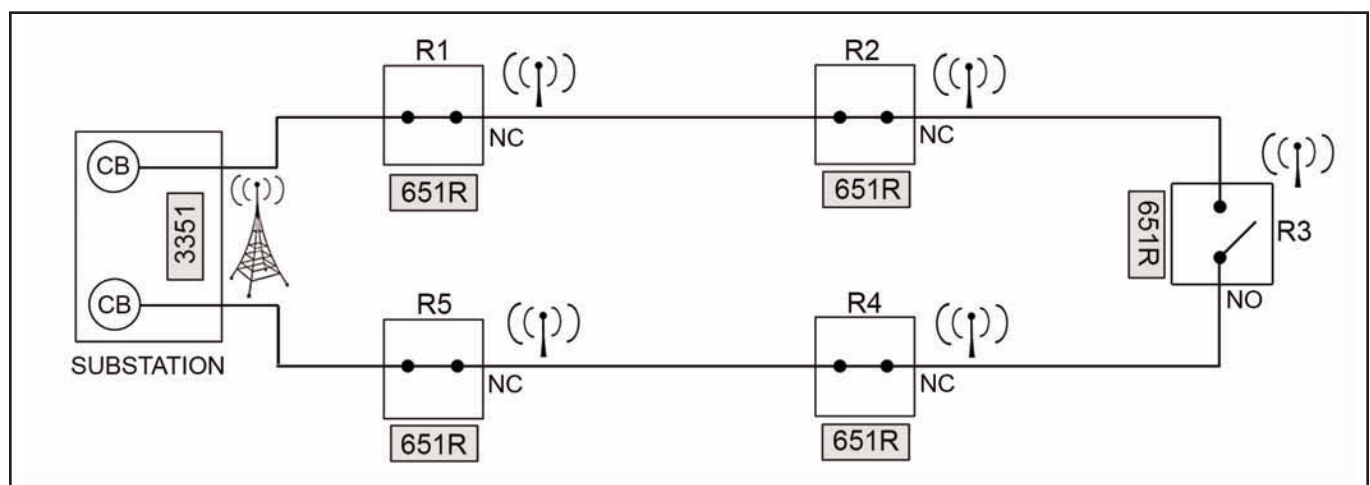

The 3351 processor communicated via radio to each of the recloser 651R controls. The 651Rs were also individually programmed to sense and isolate a fault even if communications were lost.

had potential transformers on each side of the recloser to detect loss of voltage and to provide power to the recloser if one of the lines was isolated. Radios communicating DNP protocol were used to link each recloser with the 3351 central processor at the substation.

The recloser controls were programmed with five different setting groups that could be changed by the SEL 3351 depending on the status of the circuit (i.e. lost communication, fault isolated, line restored, etc.). This ability to program different scenario parameters for each recloser enabled the restoration system to function even if communications from the central processor were to be lost.

When a fault was detected, the first recloser that sensed the fault would reclose 3 times in an attempt to clear the line. If it fault current remained present, it would open. During this process the central SEL 3351 would be alerted to the fault condition and which other reclosers detected the fault. After the reclosing Viper-ST opened, the SEL 3351 would tell the other closest recloser to the fault to open and isolate the faulted section. Once the fault was isolated, depending on where in the circuit it occurred, the

normally open recloser would close to restore power to as much of the system as possible. The maximum time required to reconfigure the circuit was within the 90 seconds requirement.

Solution Results: The utility chose to go with G&W for numerous reasons. First, the Viper reclosers were designed to work directly with the SEL controls facilitating ease of installation. The G&W Viper and SEL control combination was a time proven solution for many years. The Lazer automatic restoration package offered a pre-engineered, factory tested solution. Representatives from both G&W and SEL were on-site to commission and test the scheme. The utility had already been familiar with SEL controls from other system protection applications simplifying additional training of operating personnel. Finally, the Lazer solution was able to be fully functional even if communications were lost. All of this contributed to the utility personnel's piece of mind.

A fully functional Smart Grid FDIR scheme is now up and running. **For more information:** Contact your G&W representative or visit www.gwelec.com.